

Accessories / Optional

TCT saw blade for table top miter saw

EFFICUT

★★★★★

Outer (mm)	No. teeth	Kerf (mm)	Hole (mm)	Ring (mm)	Sales pkg q'ty	Part No.
260	45	2.15	25.4	15.88	1	E-27779
	60	2.15	25.4	-	1	E-29555
	80	2.15	25.4	-	1	E-29583
	45	2.15	30	-	1	E-27763
	60	2.15	30	25.4 15.88	1	E-29549
	80	2.15	30	25.4 15.88	1	E-29577



345709-0
Set plate



322312-4
Holder



781044-6
Hex. wrench 6



122536-0
Vise assembly



122852-0
Dust bag assembly



345709-0
Set plate

Advanced Dustless Solution



+



Can be directly connected to a hose pipe with "Front cuff 38"



Can be connected to a hose pipe by replacing the Front cuff 22 with "Front cuff 38"



Vacuum Cleaner with "Front cuffs 38" in the hose pipe

Cordless Table Top Miter Saw	
LH001G	
	Wheel diameter 255 mm (10"), 260 mm (10-1/4")
	No load speed 4,300 min ⁻¹
	Maximum Output : W 2,100
	Miter saw specifications / Bevel range 0° - Left : 45°
	Miter saw specifications / Miter range Left: 45° / Right: 52°
	Miter saw specifications / Cutting capacity Bevel 0° / Miter 0°: 69 x 130 mm (2-3/4 x 5-1/8"), 93 x 95 mm (3-5/8 x 3-3/4")
	Bevel 0° / Miter 45°LR: 69 x 85 mm (2-3/4 x 3-3/8"), 93 x 67 mm (3-5/8 x 2-5/8")
	Sound pressure level 91 dB(A) (EN62841-3-11)
	Sound power level 103 dB(A) (EN62841-3-11)
	Uncertainty (K) for Noise 3 dB(A) (EN62841-3-11)
	Table saw, Max cutting capacity 40 mm (1-9/16")
	Table saw, Table size 260 x 415 mm (10-1/4 x 16-3/8")
	Dimensions (L x W x H) (Battery) 545 x 476 x 585 mm (21-1/2 x 18-3/4 x 23") (BL4040)
	Net weight (Battery) 14.8 - 16.0 kg (32.6 - 35.3 lbs.) (BL4020 - BL4080F)

Standard Equipment : LH001GZ : Vise assembly: 122536-0(1), Dust bag assembly: 122852-0(1), Holder: 322312-4(1), Set plate: 345709-0(1), Push stick 416772-1(1), Hex. wrench 6 781044-6(1), TCT SAW EFFICUT 260X45T E-27779(1)

Charging Time

Battery	Fast Charging	
	DC40RA	DC40RC
BL4020 2.0Ah	22 min	30 min
*1 BL4025 2.5Ah	28 min	38 min
*1 BL4040/F 4.0Ah	45 min	67 min
*1 BL4050F 5.0Ah	50 min	85 min
*1 BL4080F/H 8.0Ah	76 min	170 min

*1 Recommended battery



Miter saw and Table saw in one tool with cordless convenience

Max cutting capacity

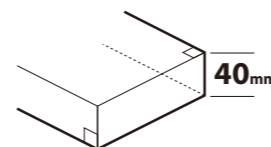

Miter saw

Work amount on a full battery charge

122 cuts

Cut 62 x 130 mm Melapi with BL4040 battery



Miter cut

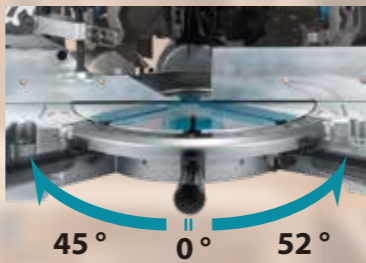

Bevel cut

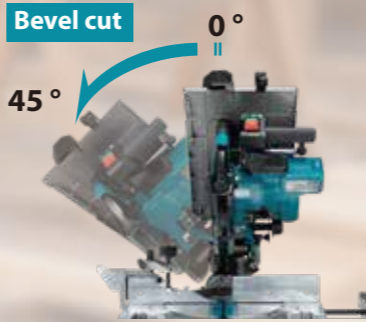

XGT 40V^{Li-ion} max + BL MOTOR

With an XGT battery, BL motor, and EFFICUT blade, the tool delivers power and efficiency that exceed those of corded models equipped with a general-purpose blade.



Lightweight at only 12.5kg (tool only)



Work efficiency*

LH001G (EFFICUT blade)

285% (3.2 sec)

Our AC model (General-purpose blade)

100%

*Test condition: Table saw mode, Test material: Melapi (40 x 500mm)



Auto-start Wireless System

Connects to a compatible vacuum cleaner with Bluetooth. The vacuum cleaner automatically runs while the switch is on.

Table saw

Work amount on a full battery charge

60 cuts

Cut 40 x 500mm Melapi with BL4040 battery



Rip fence secured at both ends

Minimizes bending when the workpiece is pressed against it, enhancing cutting accuracy in table saw mode.

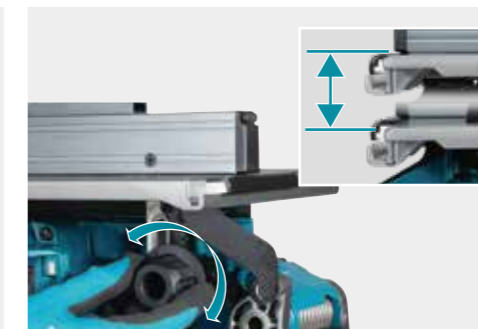
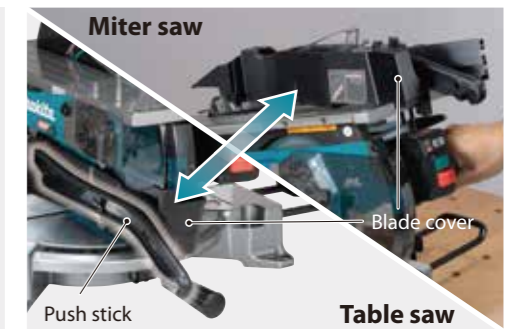

Table height adjustment

A rack-and-pinion mechanism allows easy fine adjustment of the table height by simply turning the knob.



Blade cover for both modes

The blade cover is used in Miter saw and Table saw modes. The push stick can be stored on the side of the blade cover to help avoid loss.



Enhanced dust-collection efficiency

A redesigned airflow path minimizes the dust ejected from the blade cover, enhancing dust-collection efficiency in table saw mode.



Vacuum cleaner activation switch

The switch that activates only the vacuum cleaner via AWS makes it easier to clean the tool after use.



LED job light with cut line guide

An LED light casts the blade's shadow on the workpiece, allowing the blade to be aligned with the marked cut line.