

INSTRUCTION MANUAL

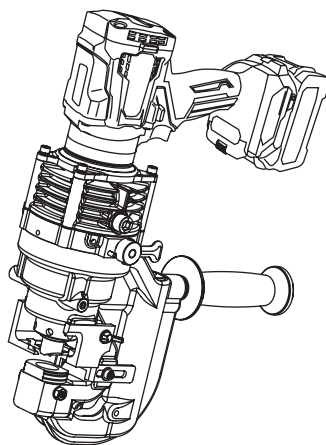

Cordless Hole Puncher

PP001G



Read before use.

SPECIFICATIONS

Model:		PP001G
Max. throat depth		40 mm
Shape of holes		Round / Oblong
Max. hole size and thickness	For mild steel of 65,000 psi tensile strength	Diameter : 20 mm Thickness : 9 mm
	For stainless steel of 89,000 psi tensile strength	Diameter : 20 mm Thickness : 6 mm
Rated voltage		D.C. 36 V - 40 V max
Dimensions (L x W x H) (with handle)		398 mm x 129 mm x 315 mm
Net weight		11.6 - 11.96 kg

- Due to our continuing program of research and development, the specifications herein are subject to change without notice.
- Specifications may differ from country to country.
- The weight may differ depending on the attachment(s), including the battery cartridge. The lightest and heaviest combinations, according to EPTA-Procedure 01/2014, are shown in the table.

Applicable battery cartridge and charger







Battery cartridge	BL4025 / BL4040
Charger	DC40RA

- Some of the battery cartridges and chargers listed above may not be available depending on your region of residence.

⚠WARNING: Only use the battery cartridges and chargers listed above. Use of any other battery cartridges and chargers may cause injury and/or fire.

Combination of punch and die







Round punching

Punch	Die	Workpiece	Capacity
		Flat bar 	Max: 80 mm x t9 (Center punching)
		Angle 	Min: 40 mm x 40 mm x t3 Max: 80 mm x 80 mm x t9
		Channel 	Min: 75 mm x 40 mm Max: 125 mm x 65 mm (Flange punching)
		H-steel 	Min: 100 mm x 100 mm Max: 300 mm x 150 mm

Unit: mm

Punch	Die	Tensile	Channel	Tensile
		Mild Steel (65,000 psi)		Stainless Steel (89,000 psi)
6	SB6	t2 - t4	-	t3 - t4
6.5	SB6.5	t2 - t6	-	t3 - t4
8	SB8	t2 - t6	-	t3 - t4
8.5	SB8.5	t2 - t6	-	t3 - t4
10	SB10	t2 - t6	t8	t3 - t4
11	SB11	t2 - t9	t8	t3 - t6
12	SB12	t2 - t9	t8	t3 - t6
13	SB13	t2 - t9	t8	t3 - t6
14	SB14	t2 - t9	t8	t3 - t6
15	SB15	t2 - t9	t8	t3 - t6
16	SB16	t2 - t9	t8	t3 - t6
18	SB18	t2 - t9	t8	t3 - t6
19	SB19	t2 - t9	t8	t3 - t6
20	SB20	t2 - t9	t8	t3 - t6







Oblong punching

Punch	Die	Workpiece	Capacity
		Flat bar 	Max: 80 mm x t9 (Center punching)
		Angle 	Min: 40 mm x 40 mm x t3 Max: 80 mm x 80 mm x t9
		Channel 	Min: 75 mm x 40 mm Max: 125 mm x 65 mm (Flange punching)
		H-steel 	Min: 100 mm x 100 mm Max: 300 mm x 150 mm

Unit: mm

Punch	Die	Tensile	Channel	Tensile
		Mild Steel (65,000 psi)		Stainless Steel (89,000 psi)
6.5 x 10	6.5 x 10B	t2 - t6	-	t3 - t4
6.5 x 13	6.5 x 13B	t2 - t6	-	t3 - t4
8.5 x 13	8.5 x 13B	t2 - t6	-	t3 - t4
8.5 x 17	8.5 x 17B	t2 - t6	-	t3 - t4
9 x 13.5	9 x 13.5B	t2 - t6	-	t3 - t4
9 x 18	9 x 18B	t2 - t6	-	t3 - t4
10 x 15	10 x 15B	t2 - t8	t8	t3 - t6
10 x 20	10 x 20B	t2 - t8	t8	t3 - t6
11 x 16.5	11 x 16.5B	t2 - t9	t8	t3 - t6
12 x 18	12 x 18B	t2 - t9	t8	t3 - t6
13 x 19.5	13 x 19.5B	t2 - t9	t8	t3 - t6
14 x 21	14 x 21B	t2 - t9	t8	t3 - t6
15 x 21	15 x 21B	t2 - t9	t8	t3 - t6

Vertical oblong punching





Punch	Die	Workpiece	Capacity
		Flat bar 	Max: 80 mm x t9 (Center punching)
		Angle 	Min: 40 mm x 40 mm x t3 Max: 80 mm x 80 mm x t9
		Channel 	Min: 75 mm x 40 mm Max: 125 mm x 65 mm (Flange punching)
		H-steel 	Min: 100 mm x 100 mm Max: 300 mm x 150 mm

Unit: mm

Punch	Die	Tensile	Channel	Tensile
		Mild Steel (65,000 psi)		Stainless Steel (89,000 psi)
TN12 x 20	TN12 x 20B	t2 - t9	t8	t3 - t6
TN14 x 20	TN14 x 20B	t2 - t9	t8	t3 - t6

Symbols

The followings show the symbols which may be used for the equipment. Be sure that you understand their meaning before use.

	Read instruction manual.
	Flying debris and loud noise hazards. Wear ear and eye protection.
	Hazardous voltage. Disconnect all power before working on this equipment. Failure to observe this instruction may result in death or personal injury.
	Moving blade. Keep hands clear while machine is operating. Turn power off before servicing.



Only for EU countries

Due to the presence of hazardous components in the equipment, waste electrical and electronic equipment, accumulators and batteries may have a negative impact on the environment and human health. Do not dispose of electrical and electronic appliances or batteries with household waste!

In accordance with the European Directive on waste electrical and electronic equipment and on accumulators and batteries and waste accumulators and batteries, as well as their adaptation to national law, waste electrical equipment, batteries and accumulators should be stored separately and delivered to a separate collection point for municipal waste, operating in accordance with the regulations on environmental protection.

This is indicated by the symbol of the crossed-out wheeled bin placed on the equipment.

Intended use

This tool is intended for piercing a hole on steel material.

SAFETY WARNINGS

General power tool safety warnings

⚠WARNING Read all safety warnings, instructions, illustrations and specifications provided with this power tool. Failure to follow all instructions listed below may result in electric shock, fire and/or serious injury.

Save all warnings and instructions for future reference.

The term "power tool" in the warnings refers to your mains-operated (corded) power tool or battery-operated (cordless) power tool.

Work area safety

1. **Keep work area clean and well lit.** Cluttered or dark areas invite accidents.
2. **Do not operate power tools in explosive atmospheres, such as in the presence of flammable liquids, gases or dust.** Power tools create sparks which may ignite the dust or fumes.
3. **Keep children and bystanders away while operating a power tool.** Distractions can cause you to lose control.

Electrical safety

1. **Power tool plugs must match the outlet. Never modify the plug in any way. Do not use any adapter plugs with earthed (grounded) power tools.** Unmodified plugs and matching outlets will reduce risk of electric shock.
2. **Avoid body contact with earthed or grounded surfaces, such as pipes, radiators, ranges and refrigerators.** There is an increased risk of electric shock if your body is earthed or grounded.
3. **Do not expose power tools to rain or wet conditions.** Water entering a power tool will increase the risk of electric shock.
4. **Do not abuse the cord. Never use the cord for carrying, pulling or unplugging the power tool. Keep cord away from heat, oil, sharp edges or moving parts.** Damaged or entangled cords increase the risk of electric shock.
5. **When operating a power tool outdoors, use an extension cord suitable for outdoor use.** Use of a cord suitable for outdoor use reduces the risk of electric shock.
6. **If operating a power tool in a damp location is unavoidable, use a residual current device (RCD) protected supply.** Use of an RCD reduces the risk of electric shock.
7. **Power tools can produce electromagnetic fields (EMF) that are not harmful to the user.** However, users of pacemakers and other similar medical devices should contact the maker of their device and/or doctor for advice before operating this power tool.

Personal safety

1. **Stay alert, watch what you are doing and use common sense when operating a power tool. Do not use a power tool while you are tired or under the influence of drugs, alcohol or**

medication. A moment of inattention while operating power tools may result in serious personal injury.

2. **Use personal protective equipment. Always wear eye protection.** Protective equipment such as a dust mask, non-skid safety shoes, hard hat or hearing protection used for appropriate conditions will reduce personal injuries.
3. **Prevent unintentional starting. Ensure the switch is in the off-position before connecting to power source and/or battery pack, picking up or carrying the tool.** Carrying power tools with your finger on the switch or energising power tools that have the switch on invites accidents.
4. **Remove any adjusting key or wrench before turning the power tool on.** A wrench or a key left attached to a rotating part of the power tool may result in personal injury.
5. **Do not overreach. Keep proper footing and balance at all times.** This enables better control of the power tool in unexpected situations.
6. **Dress properly. Do not wear loose clothing or jewellery. Keep your hair and clothing away from moving parts.** Loose clothes, jewellery or long hair can be caught in moving parts.
7. **If devices are provided for the connection of dust extraction and collection facilities, ensure these are connected and properly used.** Use of dust collection can reduce dust-related hazards.
8. **Do not let familiarity gained from frequent use of tools allow you to become complacent and ignore tool safety principles.** A careless action can cause severe injury within a fraction of a second.
9. **Always wear protective goggles to protect your eyes from injury when using power tools. The goggles must comply with ANSI Z87.1 in the USA, EN 166 in Europe, or AS/NZS 1336 in Australia/New Zealand. In Australia/New Zealand, it is legally required to wear a face shield to protect your face, too.**

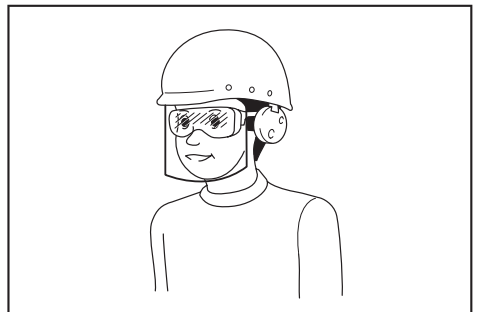

It is an employer's responsibility to enforce the use of appropriate safety protective equipments by the tool operators and by other persons in the immediate working area.

Power tool use and care

1. **Do not force the power tool. Use the correct power tool for your application.** The correct power tool will do the job better and safer at the rate for which it was designed.

2. **Do not use the power tool if the switch does not turn it on and off.** Any power tool that cannot be controlled with the switch is dangerous and must be repaired.
3. **Disconnect the plug from the power source and/or remove the battery pack, if detachable, from the power tool before making any adjustments, changing accessories, or storing power tools.** Such preventive safety measures reduce the risk of starting the power tool accidentally.
4. **Store idle power tools out of the reach of children and do not allow persons unfamiliar with the power tool or these instructions to operate the power tool.** Power tools are dangerous in the hands of untrained users.
5. **Maintain power tools and accessories. Check for misalignment or binding of moving parts, breakage of parts and any other condition that may affect the power tool's operation. If damaged, have the power tool repaired before use.** Many accidents are caused by poorly maintained power tools.
6. **Keep cutting tools sharp and clean.** Properly maintained cutting tools with sharp cutting edges are less likely to bind and are easier to control.
7. **Use the power tool, accessories and tool bits etc. in accordance with these instructions, taking into account the working conditions and the work to be performed.** Use of the power tool for operations different from those intended could result in a hazardous situation.
8. **Keep handles and grasping surfaces dry, clean and free from oil and grease.** Slippery handles and grasping surfaces do not allow for safe handling and control of the tool in unexpected situations.
9. **When using the tool, do not wear cloth work gloves which may be entangled.** The entanglement of cloth work gloves in the moving parts may result in personal injury.

Battery tool use and care

1. **Recharge only with the charger specified by the manufacturer.** A charger that is suitable for one type of battery pack may create a risk of fire when used with another battery pack.
2. **Use power tools only with specifically designated battery packs.** Use of any other battery packs may create a risk of injury and fire.
3. **When battery pack is not in use, keep it away from other metal objects, like paper clips, coins, keys, nails, screws or other small metal objects, that can make a connection from one terminal to another.** Shorting the battery terminals together may cause burns or a fire.
4. **Under abusive conditions, liquid may be ejected from the battery; avoid contact.** If contact accidentally occurs, flush with water. If liquid contacts eyes, additionally seek medical help. Liquid ejected from the battery may cause irritation or burns.
5. **Do not use a battery pack or tool that is damaged or modified.** Damaged or modified batteries may exhibit unpredictable behaviour resulting in fire, explosion or risk of injury.
6. **Do not expose a battery pack or tool to fire or excessive temperature.** Exposure to fire or temperature above 130 °C may cause explosion.
7. **Follow all charging instructions and do not charge the battery pack or tool outside the temperature range specified in the instructions.** Charging improperly or at temperatures outside the specified range may damage the battery and increase the risk of fire.

Service

1. **Have your power tool serviced by a qualified repair person using only identical replacement parts.** This will ensure that the safety of the power tool is maintained.
2. **Never service damaged battery packs.** Service of battery packs should only be performed by the manufacturer or authorized service providers.
3. **Follow instruction for lubricating and changing accessories.**

Safety instructions for Cordless Hole Puncher

1. **Proper selection of the punch and the die is essential. Select the correct punch and die according to the hole shape, size of hole, workpiece thickness and material type.**
2. **Ensure that any punch with stepped edge, which prevents free rotation, is installed correctly in the punch piston before tightening the punch retaining nut.**
3. **For punching channel-shaped workpiece and the workpiece made of stainless steel, use the die provided exclusively for these materials. Only select the combination of the punch and die that is suitable for the workpiece thickness.**
4. **Ensure the punch and the die are firmly fixed in position with the nut or the bolt.** Failure to do so may cause serious damage to your tool and serious personal injury. Regularly check and tighten the punch and die.
5. **The tool is electro-hydraulic. When the temperature is cold, it should be run for a few minutes at idle before starting operations.**
6. **Keep face, hands and other parts of your body away from the punching area during operation.**
7. **Remove the battery cartridge before changing the punch and the die or when servicing or making adjustments.**
8. **The punch and the die that become worn, deformed, nicked, broken or damaged in any way may cause a tool breakdown and a serious accident. Replace them immediately with new ones supplied from Makita.**
9. **When punching stainless steel, the punch and die may wear earlier than punching softer materials. Ensure that the punch and die are in good condition, free from wear and are not deformed, nicked, broken or damaged in any way. Check with your dealer before punching any material not listed in the specifications.**
10. **When using the tool continuously, its temperature can exceed 70 °C which may cause lower**

performance. In this case, stop operating for about 1 hour to allow the tool to cool down before using it again.

11. Do not cover or clog the motor air vents as this may cause the motor to overheat, resulting in smoke, fire and explosion.

Important safety instructions for battery cartridge

1. Before using battery cartridge, read all instructions and cautionary markings on (1) battery charger, (2) battery, and (3) product using battery.
2. Do not disassemble or tamper with the battery cartridge. It may result in a fire, excessive heat, or explosion.
3. If operating time has become excessively shorter, stop operating immediately. It may result in a risk of overheating, possible burns and even an explosion.
4. If electrolyte gets into your eyes, rinse them out with clear water and seek medical attention right away. It may result in loss of your eyesight.
5. Do not short the battery cartridge:
 - (1) Do not touch the terminals with any conductive material.
 - (2) Avoid storing battery cartridge in a container with other metal objects such as nails, coins, etc.
 - (3) Do not expose battery cartridge to water or rain.

A battery short can cause a large current flow, overheating, possible burns and even a breakdown.

6. Do not store and use the tool and battery cartridge in locations where the temperature may reach or exceed 50 °C (122 °F).
7. Do not incinerate the battery cartridge even if it is severely damaged or is completely worn out. The battery cartridge can explode in a fire.
8. Do not nail, cut, crush, throw, drop the battery cartridge, or hit against a hard object to the battery cartridge. Such conduct may result in a fire, excessive heat, or explosion.
9. Do not use a damaged battery.
10. The contained lithium-ion batteries are subject to the Dangerous Goods Legislation requirements.

For commercial transports e.g. by third parties, forwarding agents, special requirement on packaging and labeling must be observed.

For preparation of the item being shipped, consulting an expert for hazardous material is required. Please also observe possibly more detailed national regulations.

Tape or mask off open contacts and pack up the battery in such a manner that it cannot move around in the packaging.

11. When disposing the battery cartridge, remove it from the tool and dispose of it in a safe place. Follow your local regulations relating to disposal of battery.

12. Use the batteries only with the products specified by Makita. Installing the batteries to non-compliant products may result in a fire, excessive heat, explosion, or leak of electrolyte.
13. If the tool is not used for a long period of time, the battery must be removed from the tool.
14. During and after use, the battery cartridge may take on heat which can cause burns or low temperature burns. Pay attention to the handling of hot battery cartridges.
15. Do not touch the terminal of the tool immediately after use as it may get hot enough to cause burns.
16. Do not allow chips, dust, or soil stuck into the terminals, holes, and grooves of the battery cartridge. It may cause heating, catching fire, burst and malfunction of the tool or battery cartridge, resulting in burns or personal injury.
17. Unless the tool supports the use near high-voltage electrical power lines, do not use the battery cartridge near high-voltage electrical power lines. It may result in a malfunction or breakdown of the tool or battery cartridge.
18. Keep the battery away from children.

SAVE THESE INSTRUCTIONS.



CAUTION: Only use genuine Makita batteries. Use of non-genuine Makita batteries, or batteries that have been altered, may result in the battery bursting causing fires, personal injury and damage. It will also void the Makita warranty for the Makita tool and charger.

Tips for maintaining maximum battery life

1. Charge the battery cartridge before completely discharged. Always stop tool operation and charge the battery cartridge when you notice less tool power.
2. Never recharge a fully charged battery cartridge. Overcharging shortens the battery service life.
3. Charge the battery cartridge with room temperature at 10 °C - 40 °C (50 °F - 104 °F). Let a hot battery cartridge cool down before charging it.
4. When not using the battery cartridge, remove it from the tool or the charger.
5. Charge the battery cartridge if you do not use it for a long period (more than six months).

PARTS DESCRIPTION

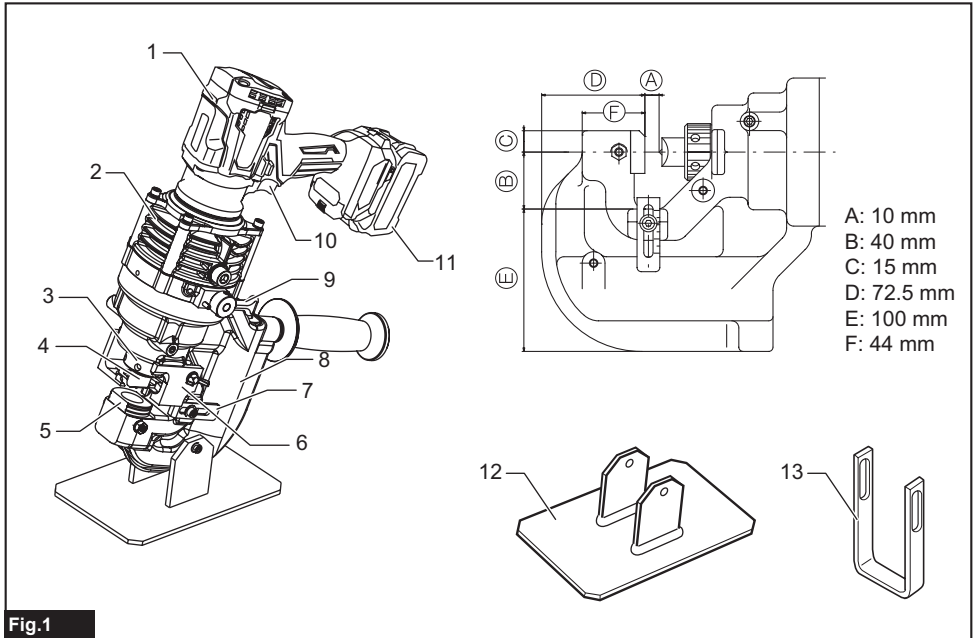

Fig.1

1	Motor	2	Pump case	3	Punch retaining nut	4	Punch
5	Die	6	Stripper	7	Slide stopper	8	C frame
9	Return lever	10	Switch trigger	11	Battery cartridge	12	Work stand (Optional accessory)
13	Slide stopper (Max. throat depth) (Optional accessory)	-	-	-	-	-	-

FUNCTIONAL DESCRIPTION

CAUTION: Always be sure that the tool is switched off and the battery cartridge is removed before adjusting or checking function on the tool.

Installing or removing battery cartridge

CAUTION: Always switch off the tool before installing or removing of the battery cartridge.

CAUTION: Hold the tool and the battery cartridge firmly when installing or removing battery cartridge. Failure to hold the tool and the battery cartridge firmly may cause them to slip off your hands and result in damage to the tool and battery cartridge and a personal injury.

To install the battery cartridge, align the tongue on the battery cartridge with the groove in the housing and slip it into place. Insert it all the way until it locks in place with a little click. If you can see the red indicator as shown in the figure, it is not locked completely.

To remove the battery cartridge, slide it from the tool while sliding the button on the front of the cartridge.

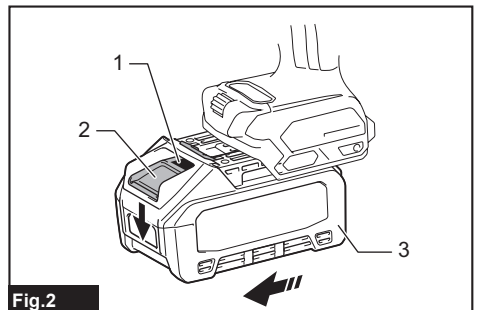

Fig.2

► 1. Red indicator 2. Button 3. Battery cartridge

CAUTION: Always install the battery cartridge fully until the red indicator cannot be seen. If not, it may accidentally fall out of the tool, causing injury to you or someone around you.

CAUTION: Do not install the battery cartridge forcibly. If the cartridge does not slide in easily, it is not being inserted correctly.

Battery protection system

The tool is equipped with a battery protection system. This system automatically cuts off power to the motor to extend tool and battery life. The tool will automatically stop during operation if the tool or battery is placed under the following condition.

Overdischarge protection

When the battery capacity is not enough, the tool stops automatically. In this case, remove the battery from the tool and charge the battery.

Protections against other causes

Protection system is also designed for other causes that could damage the tool and allows the tool to stop automatically. Take all the following steps to clear the causes, when the tool has been brought to a temporary halt or stop in operation.

1. Make sure that all switch(es) is/are in the off position, and then turn the tool on again to restart.
2. Charge the battery(ies) or replace it/them with recharged battery(ies).
3. Let the tool and battery(ies) cool down.

If no improvement can be found by restoring protection system, then contact your local Makita Service Center.

Indicating the remaining battery capacity

Press the check button on the battery cartridge to indicate the remaining battery capacity. The indicator lamps light up for a few seconds.

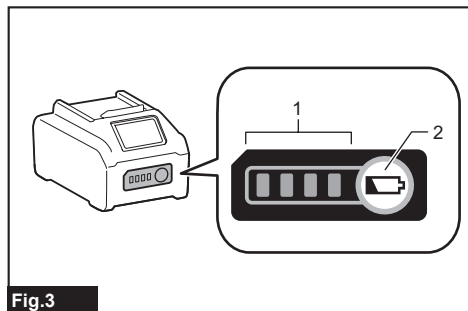

Fig.3

► 1. Indicator lamps 2. Check button

Indicator lamps			Remaining capacity
Lighted	Off	Blinking	
■ ■ ■ ■			75% to 100%
■ ■ ■ □			50% to 75%
■ ■ □ □			25% to 50%
■ □ □ □			0% to 25%
▣ □ □ □			Charge the battery.
■ ■ □ □			The battery may have malfunctioned.
□ □ ■ ■	↑ ↓		

NOTE: Depending on the conditions of use and the ambient temperature, the indication may differ slightly from the actual capacity.

NOTE: The first (far left) indicator lamp will blink when the battery protection system works.

Switch action

CAUTION: Before installing the battery cartridge into the tool, always check to see that the switch trigger actuates properly and returns to the "OFF" position when released.

CAUTION: Always lock the switch trigger when not in use.

When punching a workpiece, continue to pull the switch trigger until the punch goes down to the die and returns to the start position.

To lock the switch trigger, push in the trigger lock button from B side. To unlock, push in the trigger lock button from A side.

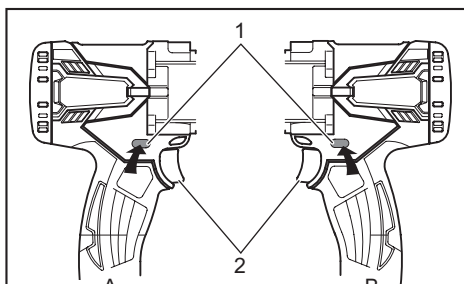

Fig.4

► 1. Trigger lock button 2. Switch trigger

Rotatable grip

The grip can be rotated through 360 degrees, in either direction, during operation. This feature is particularly useful when working in awkward or narrow areas as it allows the operator to position the tool in the best position for easy operation.

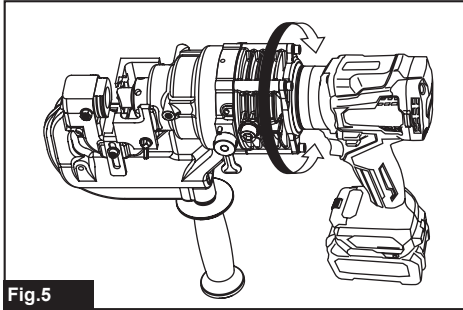

Fig.5

ASSEMBLY

CAUTION: Always be sure that the tool is switched off and the battery cartridge is removed before carrying out any work on the tool.

Replacing the punch and die

Replacing round punch

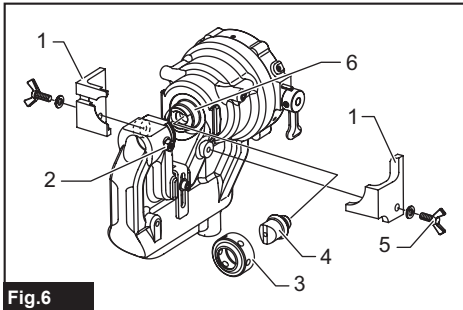

Fig.6

- 1. Stripper 2. Nut and set bolt 3. Punch retaining nut
4. Round punch 5. Butterfly bolt 6. Punch rod

1. Be sure that the punch piston is fully retracted and remove the strippers to make access to the parts easier.
2. The punch must be removed first and then the die. Unscrew the punch retaining nut to remove the punch and remove the set bolt and the nut to remove the die.

NOTICE: When replacing the punch and the die, make sure that the correct size, thickness and hole shape is selected. Shaped punches and dies must be properly aligned with each other.

3. Place the die in the C frame in the proper orientation. Secure firmly with the set bolt and tighten the nut.

4. Place the punch in the punch retaining nut. Insert the punch with the nut into the punch piston and hand tighten the nut.

NOTICE: When installing a punch with a stepped edge (anti rotation), make sure the orientation is correct and that the stepped edge is correctly positioned in the punch piston.

5. Make sure the punch is correctly positioned in the punch rod and tighten the punch retaining nut firmly with the nut retaining bar supplied.

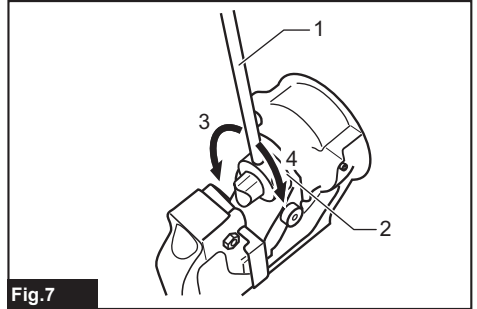

Fig.7

- 1. Nut retaining bar 2. Punch retaining nut
3. Loosen 4. Tighten

6. Restore the strippers.

WARNING: If the punch and die are not the same size or the punch and the die are not positioned properly, the punch may strike the die causing both parts to break. In such a case, pieces flying off from the broken parts may cause personal injury.

CAUTION: Check the butterfly bolts which hold the stripper regularly to ensure that they are tight. Loose bolts may cause the stripper to come off and damage the tool.

Replacing oblong punch

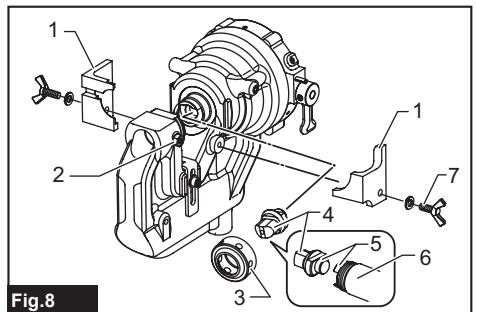

Fig.8

- 1. Stripper 2. Nut and set bolt 3. Punch retaining nut
4. Oblong punch 5. Stepped edge 6. Punch rod
7. Butterfly bolt

1. Be sure that the punch piston is fully retracted and remove the strippers to make access to the parts easier.

2. The punch must be removed first and then the die. Unscrew the punch retaining nut to remove the punch and remove the set bolt and the nut to remove the die.

NOTICE: When replacing the punch and the die, make sure that the correct size, thickness and hole shape is selected. Shaped punches and dies must be properly aligned with each other.

3. Secure the oblong die firmly with the set bolt and tighten the nut.

4. Place the oblong punch into the punch retaining nut. Position the stepped edge of the oblong punch properly in the punch piston and hand tighten the punch retaining nut.

NOTICE: If the stepped edge of the oblong punch is not properly inserted into the punch piston, the punch retaining nut cannot be fastened. Make sure the oblong punch is positioned correctly in the punch rod.

5. Push the oblong punch against the punch rod and tighten the punch retaining nut firmly with the nut retaining bar supplied.

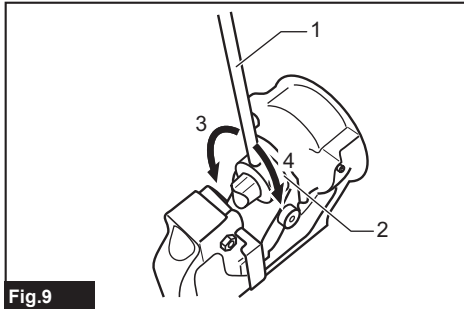

Fig.9

► 1. Nut retaining bar 2. Punch retaining nut
3. Loosen 4. Tighten

6. Restore the strippers.

WARNING: If the punch and die are not the same size or the punch and the die are not positioned properly, the punch may strike the die causing both parts to break. In such a case, pieces flying off from the broken parts may cause personal injury.

CAUTION: Check the butterfly bolts which hold the stripper regularly to ensure that they are tight. Loose bolts may cause the stripper to come off and damage the tool.

CAUTION: Make sure the stepped edge of the oblong punch is positioned correctly in the punch rod and the punch retaining nut is properly fastened.

OPERATION

Correct use of the tool

Die selection

It is important that the die to be used is correct for the thickness of the workpiece to be punched. Punching the workpiece of 4 mm to 8 mm thickness using a die for thinner workpiece can cause the punch to jam in the workpiece. This is due to the smaller clearance between the die and punch. In such a case, the workpiece will be pulled up by the retracting punch as shown in the figure. Special care should be taken when punching flat bar of mild steel, aluminum and copper.

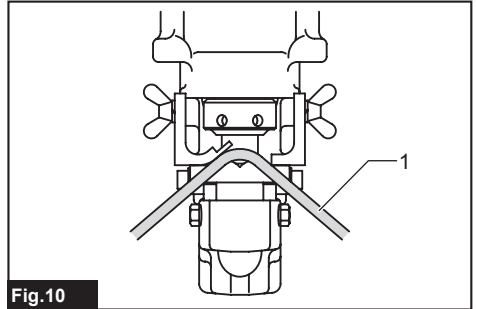

Fig.10

► 1. Workpiece

Correct use of the stripper

Do not position the workpiece with one end or both ends unsupported by the stripper. If the workpiece is not properly supported, it will move when the punch returns. It may cause the punch to jam and damaging the tool.

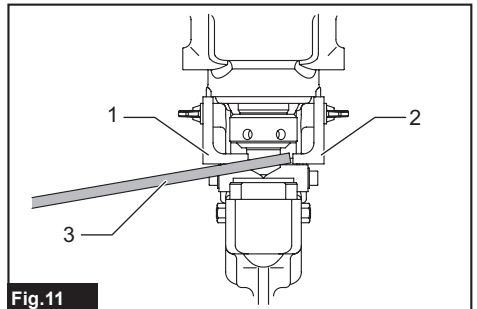

Fig.11

► 1. Stripper L 2. Stripper R 3. Workpiece

Punching a hole

CAUTION: Before punching, always make sure that the proper punch and die are installed correctly.

1. Check the position for punching.

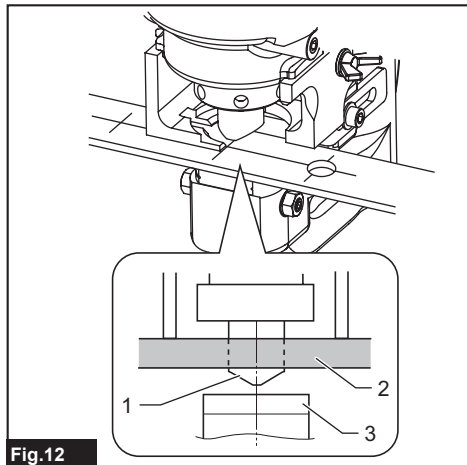

Fig.12

- 1. Punch 2. Flat bar 3. Die

2. Loosen the cap screw on the slide stopper and adjust the slide stopper to the desired position. After that, retighten the cap screw.

NOTE: The slide stopper is set to hold the hole puncher at a constant distance from the edge of the work piece.

3. Check that the return lever is fully closed in the clockwise direction.

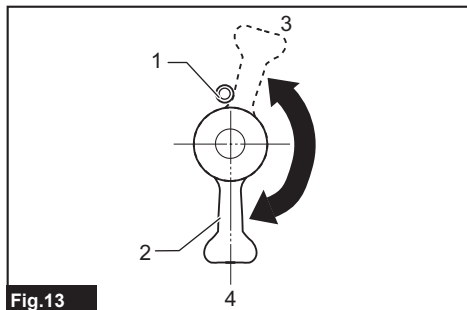

Fig.13

- 1. Spring pin 2. Return lever 3. Open position 4. Closed position

4. Check that the punch piston is fully retracted.
5. Place the puncher in the required position on the workpiece using the slide stopper as a guide. Align the point of the punch with the center mark of the hole to be punched.
6. Continue to pull the switch trigger until the punch reaches the end of its stroke and returns to the starting position.

The punch rod will extend and push the punch through the workpiece.

NOTE: To aid accurate and easy positioning of the punch, pull the switch trigger intermittently to jog the punch down to the workpiece. If the position is not satisfactory, open the return lever to retract the punch for another attempt. If the punch doesn't return to its starting position with return lever open, pull the switch trigger to return the punch.

NOTE: If the punch doesn't return after punching finishes, release the switch trigger to stop the motor and pull the switch trigger again.

If the punch doesn't return even after performing above procedures, perform the procedures for stopping the operation before the completion of punching mentioned below.

Stopping the operation before the punching is finished

If you want to stop the operation before the punching is finished, perform the procedures below:

1. Turn the return lever counterclockwise until it hits the spring pin and then immediately back to its starting position.

Doing this releases the internal pressure of the tool. If the punch retracts from the workpiece under its own power, allow the punch to fully return. After that, turn the return lever back to its starting position. In this case, the following step is not necessary.

2. Continue to pull the switch trigger until the punch returns to its starting position.

Using slide stopper for maximum depth

Optional accessory

CAUTION: Before attaching or removing the slide stopper, ensure that the battery cartridge is removed to prevent accidental operation and personal injury.

Punching up to 40 mm depth from the edge of the workpiece can be done using the optional slide stopper.

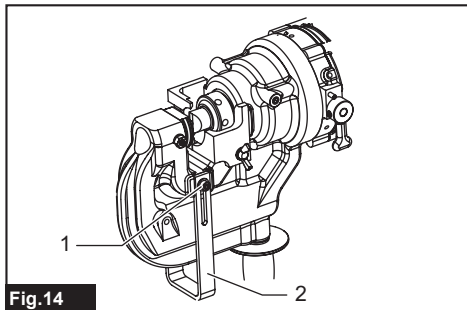

Fig.14

- 1. Bolt and washer 2. Optional slide stopper

1. Loosen the set bolt and nut to remove the die.

2. Remove the bolt and washer fixing the slide stopper.
3. Remove the slide stopper by pulling it to the upper side of the C frame.
4. Insert the optional slide stopper for maximum depth from the bottom side of the C frame.
5. Fix the optional slide stopper with the bolt and washer removed in step 2.
6. Install the die with the set bolt and nut removed in step 1.

MAINTENANCE

CAUTION: Always be sure that the tool is switched off and the battery cartridge is removed before attempting to perform inspection or maintenance.

NOTICE: Never use gasoline, benzene, thinner, alcohol or the like. Discoloration, deformation or cracks may result.

To maintain product SAFETY and RELIABILITY, repairs, any other maintenance or adjustment should be performed by Makita Authorized or Factory Service Centers, always using Makita replacement parts.

Regular maintenance

Keep the air hole at the end of the C frame clear of dirt and obstructions. The air hole has to be open in order to control the hydraulic pressure.

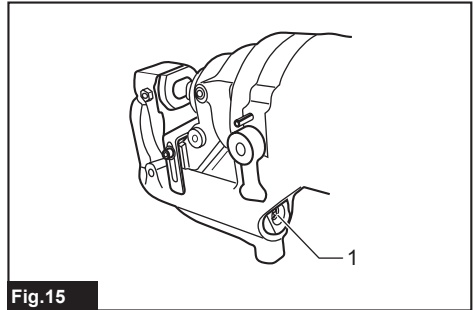

Fig.15

► 1. Air hole

TROUBLESHOOTING

Before asking for repairs, conduct your own inspection first. If you find a problem that is not explained in the manual, do not attempt to dismantle the tool. Instead, ask Makita Authorized Service Centers, always using Makita replacement parts for repairs.

State of abnormality	Probable cause (malfunction)	Remedy
Punch piston will not come out.	Punch piston has not returned completely due to rebar chips, iron powder and dirt in the sliding portion of punch piston and C frame.	Push back punch piston. Clean punch piston.
	Punch piston has not returned completely due to the distortion or swelling of punch piston.	Ask your local authorized service center for repair.
	Punch piston has not returned completely due to weak return spring.	Ask your local authorized service center for repair.
Although punch piston comes out, cutting power is too weak to hole punching.	Contact between cylinder and release valve is improper. There may be scratches at chimney of cylinder or iron powder or dirt are sticking there.	Ask your local authorized service center for repair.
	Breakage of release valve.	Ask your local authorized service center for repair.
	Improper clearance between cylinder and piston.	Ask your local authorized service center for repair.
	Improper contact between cylinder and check valve.	Ask your local authorized service center for repair.
	Breakage of urethane packing of cylinder.	Ask your local authorized service center for repair.

State of abnormality	Probable cause (malfunction)	Remedy
Oil leaks.	Scratches on or breakage of oil leveler sack.	Ask your local authorized service center for repair.
	Scratches at sliding portion of C frame and punch piston and at back-up ring.	Ask your local authorized service center for repair.
	Breakage of O-ring at joint of C frame and cylinder.	Ask your local authorized service center for repair.
	Breakage of liner at joint of cylinder and pump case.	Ask your local authorized service center for repair.
	Insufficient tightening of bolts at respective parts.	Tighten bolts.
Motor does not move. Poor motor rotation.	Insufficient charge of battery cartridge.	Charge battery cartridge.
	Battery life cycle worn off.	Replace battery cartridge.
	Breakage of motor by overheating.	Ask your local authorized service center for repair.
	Deformation or breakage of bearings and gear connected to the motor.	Ask your local authorized service center for repair.

⚠ CAUTION: The internal components of the pump have very close clearances and are sensitive to damage from dust, dirt, contamination of the hydraulic fluid or improper handling. The disassembly of the pump housing requires special tools and training, and should only be attempted by repair personnel who have been properly trained and have the proper equipment. The improper servicing of electrical components can lead to conditions that could cause serious injury. The pump and piston components and all electrical components should be serviced only by authorized repair shop, dealer or distributor.

NOTICE: Any attempt by unauthorized personnel to service the internal components of the pump area will void the warranty.

OPTIONAL ACCESSORIES

⚠ CAUTION: These accessories or attachments are recommended for use with your Makita tool specified in this manual. The use of any other accessories or attachments might present a risk of injury to persons. Only use accessory or attachment for its stated purpose.

If you need any assistance for more details regarding these accessories, ask your local Makita Service Center.

- Work stand
- Slide stopper (Max. throat depth)
- Makita genuine battery and charger

NOTE: Some items in the list may be included in the tool package as standard accessories. They may differ from country to country.

Makita Corporation
3-11-8, Sumiyoshi-cho,
Anjo, Aichi 446-8502 Japan
www.makita.com

PP001G-
ENAU-2309
EN
20240307