

INSTRUCTION MANUAL

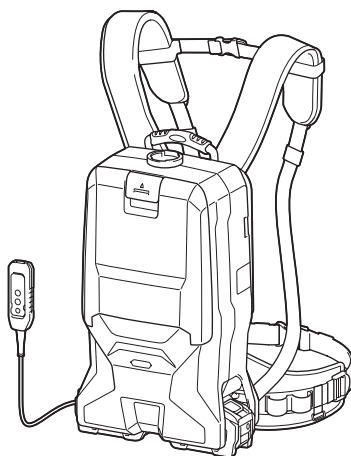

Cordless Backpack Vacuum Cleaner VC011G



  Read before use.

WARNING

- For users in Europe: This appliance can be used by children aged from 8 years and above and persons with reduced physical, sensory or mental capabilities or lack of experience and knowledge if they have been given supervision or instruction concerning use of the appliance in a safe way and understand the hazards involved. Children shall not play with the appliance. Cleaning and user maintenance shall not be made by children without supervision.
- For users in areas other than Europe: This appliance is not intended for use by persons (including children) with reduced physical, sensory or mental capabilities, or lack of experience and knowledge, unless they have been given supervision or instruction concerning use of the appliance by a person responsible for your safety.
- Children must be supervised to ensure that they do not play with the appliance.
- CAUTION: Before carrying out any maintenance operation, disconnect the appliance from the power supply. Perform maintenance on the appliance periodically.
- Rechargeable batteries must be removed from the device before charging.
- To remove or install the battery, slide the cartridge out of the tool while pressing the button on the front of the cartridge.
- Exhausted batteries must be removed from the device and disposed of safely. Follow local regulations regarding battery disposal.
- If the device is to be stored unused for a long period, the batteries should be removed.
- The power terminals must not be short-circuited.

SPECIFICATIONS

Model:	VC011G	
Capacity	Filter bag	6.0 L
	Dust bag	5.5 L
Maximum air volume (With hose \varnothing 32 mm x 1.0 m)	2.4 m ³ /min	
Vacuum	20 kPa	
Dimensions (L x W x H) (excluding the harness, with BL4050F)	336 mm x 185 mm x 543 mm	
Rated voltage	D.C. 36 V - 40 V max	
Net weight	6.4 - 9.5 kg	

- Due to our continuing program of research and development, the specifications herein are subject to change without notice.
- Specifications may differ from country to country.
- The weight does not include accessories but battery cartridge(s). The lightest and heaviest combination weight of the appliance and battery cartridge(s) are shown in the table.
- The length of supplied hose varies depending on the countries.

Applicable battery cartridge and charger

Battery cartridge	BL4020 / BL4025 / BL4040 / BL4040F / BL4050F / BL4080F
Charger	DC40RA / DC40RB / DC40RC

- Some of the battery cartridges and chargers listed above may not be available depending on your region of residence.

⚠WARNING: Only use the battery cartridges and chargers listed above. Use of any other battery cartridges and chargers may cause injury and/or fire.

⚠WARNING: Do not use a corded power supply such as battery adapter or portable power pack with this appliance. The cable of such power supply may hinder the operation and result in personal injury.

Symbols

The followings show the symbols which may be used for the equipment. Be sure that you understand their meaning before use.



Read instruction manual.



Take particular care and attention.



A representative battery applicable to this product.



Only for EU countries
Due to the presence of hazardous components in the equipment, waste electrical and electronic equipment, accumulators and batteries may have a negative impact on the environment and human health. Do not dispose of electrical and electronic appliances or batteries with household waste!

In accordance with the European Directive on waste electrical and electronic equipment and on accumulators and batteries and waste accumulators and batteries, as well as their adaptation to national law, waste electrical equipment, batteries and accumulators should be stored separately and delivered to a separate collection point for municipal waste, operating in accordance with the regulations on environmental protection.

This is indicated by the symbol of the crossed-out wheeled bin placed on the equipment.

Intended use

The appliance is intended for collecting dry dust. The appliance is suitable for commercial use, for example in hotels, schools, hospitals, factories, shops, offices and rental businesses.

Noise

The typical A-weighted noise level determined according to EN60335-2-69:

Sound pressure level (L_{pA}) : 70 dB(A) or less

Uncertainty (K) : 2.5 dB (A)

The noise level under working may exceed 80 dB (A).

NOTE: The declared noise emission value(s) has been measured in accordance with a standard test method and may be used for comparing one tool with another.

NOTE: The declared noise emission value(s) may also be used in a preliminary assessment of exposure.

⚠ WARNING: Wear ear protection.

⚠ WARNING: The noise emission during actual use of the power tool can differ from the declared value(s) depending on the ways in which the tool is used especially what kind of workpiece is processed.

⚠ WARNING: Be sure to identify safety measures to protect the operator that are based on an estimation of exposure in the actual conditions of use (taking account of all parts of the operating cycle such as the times when the tool is switched off and when it is running idle in addition to the trigger time).

Vibration

The vibration total value (tri-axial vector sum) determined according to EN60335-2-69:

Work mode: operation without load

Vibration emission ($a_{h,D}$) : 2.5 m/s² or less

Uncertainty (K) : 1.5 m/s²

NOTE: The declared vibration total value(s) has been measured in accordance with a standard test method and may be used for comparing one tool with another.

NOTE: The declared vibration total value(s) may also be used in a preliminary assessment of exposure.

⚠ WARNING: The vibration emission during actual use of the power tool can differ from the declared value(s) depending on the ways in which the tool is used especially what kind of workpiece is processed.

⚠ WARNING: Be sure to identify safety measures to protect the operator that are based on an estimation of exposure in the actual conditions of use (taking account of all parts of the operating cycle such as the times when the tool is switched off and when it is running idle in addition to the trigger time).

Declarations of Conformity

For European countries only

The Declarations of conformity are included in Annex A to this instruction manual.

SAFETY WARNINGS

Cordless vacuum cleaner safety warnings

⚠ WARNING: IMPORTANT! READ CAREFULLY all safety warnings and all instructions BEFORE USE. Failure to follow the warnings and instructions may result in electric shock, fire and/or serious injury.

1. **Before use, make sure that this cleaner must be used by people who have been adequately instructed on the use of this cleaner.**

2. Do not use the cleaner without the filter. Replace a damaged filter immediately.
 3. Do not attempt to pick up flammable materials, fireworks, lighted cigarettes, hot ashes, hot metal chips, sharp materials such as razors, needles, broken glass or the like.
 4. NEVER USE THE CLEANER IN THE VICINITY OF GASOLINE, GAS, PAINT, ADHESIVES OR OTHER HIGHLY EXPLOSIVE SUBSTANCES. The switch emits sparks when turned ON and OFF. And so does the motor commutator during operation. A dangerous explosion may result.
 5. This cleaner is not suitable for picking up hazardous dust.
 6. Never vacuum up toxic, carcinogenic, combustible or other hazardous materials such as asbestos, arsenic, barium, beryllium, lead, pesticides, or other health endangering materials.
 7. Never use the cleaner outdoors in the rain.
 8. For Finland, this machine is not to be used outdoors at low temperature.
 9. Do not use close to heat sources (stoves, etc.).
 10. Do not block cooling vents. These vents permit cooling of the motor. Blockage should be carefully avoided otherwise the motor will burn out from lack of ventilation.
 11. Keep proper footing and balance at all times.
 12. Do not fold, tug or step on the hose.
 13. Stop the cleaner immediately if you notice poor performance or anything abnormal during operation.
 14. DISCONNECT THE BATTERIES. When not in use, before servicing, and when changing accessories.
 15. Clean and service the cleaner immediately after each use to keep it in tiptop operating condition.
 16. MAINTAIN THE CLEANER WITH CARE. Keep the cleaner clean for better and safer performance. Follow instructions for changing accessories. Keep handles dry, clean, and free from oil and grease.
 17. CHECK DAMAGED PARTS. Before further use of the cleaner, a guard or other part that is damaged should be carefully checked to determine that it will operate properly and perform its intended function. Check for alignment of moving parts, binding of moving parts, breakage of parts, mounting, and any other conditions that may affect its operation. A guard or other part that is damaged should be properly repaired or replaced by an authorized service center unless otherwise indicated elsewhere in this instruction manual. Have defective switches replaced by authorized service center. Don't use the cleaner if switch does not turn it on and off.
 18. REPLACEMENT PARTS. When servicing, use only identical replacement parts.
 19. When not in use, always store the cleaner indoors.
 20. Be kind to your cleaner. Rough handling can cause breakage of even the most sturdily built cleaner.
 21. Do not attempt to clean the exterior or interior with benzene, thinner or cleaning chemicals. Cracks and discoloration may be caused.
 22. Do not use cleaner in an enclosed space where flammable, explosive or toxic vapors are given off by oil-based paint, paint-thinner, gasoline, some mothproofing substances, etc., or in areas where flammable dust is present.
 23. Do not operate the cleaner while under the influence of drugs or alcohol.
 24. As a basic rule of safety, use safety goggles or safety glasses with side shields.
 25. Use a dust mask in dusty work conditions.
 26. Never handle battery(ies) and cleaner with wet hands.
 27. Use extreme caution when cleaning on stairs.
 28. Do not use the cleaner as a stool or work bench. The machine may fall down and may result in personal injury.
- Battery tool use and care**
1. Recharge only with the charger specified by the manufacturer. A charger that is suitable for one type of battery pack may create a risk of fire when used with another battery pack.
 2. Use power tools only with specifically designated battery packs. Use of any other battery packs may create a risk of injury and fire.
 3. When battery pack is not in use, keep it away from other metal objects, like paper clips, coins, keys, nails, screws or other small metal objects, that can make a connection from one terminal to another. Shorting the battery terminals together may cause burns or a fire.
 4. Under abusive conditions, liquid may be ejected from the battery; avoid contact. If contact accidentally occurs, flush with water. If liquid contacts eyes, additionally seek medical help. Liquid ejected from the battery may cause irritation or burns.
 5. Do not use a battery pack or tool that is damaged or modified. Damaged or modified batteries may exhibit unpredictable behaviour resulting in fire, explosion or risk of injury.
 6. Do not expose a battery pack or tool to fire or excessive temperature. Exposure to fire or temperature above 130 °C may cause explosion.
 7. Follow all charging instructions and do not charge the battery pack or tool outside the temperature range specified in the instructions. Charging improperly or at temperatures outside the specified range may damage the battery and increase the risk of fire.
- Service**
1. Have your power tool serviced by a qualified repair person using only identical replacement parts. This will ensure that the safety of the power tool is maintained.
 2. Never service damaged battery packs. Service of battery packs should only be performed by the manufacturer or authorized service providers.
 3. Follow instruction for lubricating and changing accessories.
 4. Keep handles dry, clean and free from oil and grease.

Important safety instructions for battery cartridge

1. Before using battery cartridge, read all instructions and cautionary markings on (1) battery charger, (2) battery, and (3) product using battery.
2. Do not disassemble or tamper with the battery cartridge. It may result in a fire, excessive heat, or explosion.
3. If operating time has become excessively shorter, stop operating immediately. It may result in a risk of overheating, possible burns and even an explosion.
4. If electrolyte gets into your eyes, rinse them out with clear water and seek medical attention right away. It may result in loss of your eyesight.
5. Do not short the battery cartridge:
 - (1) Do not touch the terminals with any conductive material.
 - (2) Avoid storing battery cartridge in a container with other metal objects such as nails, coins, etc.
 - (3) Do not expose battery cartridge to water or rain.

A battery short can cause a large current flow, overheating, possible burns and even a breakdown.

6. Do not store and use the tool and battery cartridge in locations where the temperature may reach or exceed 50 °C (122 °F).
7. Do not incinerate the battery cartridge even if it is severely damaged or is completely worn out. The battery cartridge can explode in a fire.
8. Do not nail, cut, crush, throw, drop the battery cartridge, or hit against a hard object to the battery cartridge. Such conduct may result in a fire, excessive heat, or explosion.
9. Do not use a damaged battery.
10. The contained lithium-ion batteries are subject to the Dangerous Goods Legislation requirements.

For commercial transports e.g. by third parties, forwarding agents, special requirement on packaging and labeling must be observed.
For preparation of the item being shipped, consulting an expert for hazardous material is required. Please also observe possibly more detailed national regulations.
Tape or mask off open contacts and pack up the battery in such a manner that it cannot move around in the packaging.
11. When disposing the battery cartridge, remove it from the tool and dispose of it in a safe place. Follow your local regulations relating to disposal of battery.
12. Use the batteries only with the products specified by Makita. Installing the batteries to non-compliant products may result in a fire, excessive heat, explosion, or leak of electrolyte.

13. If the tool is not used for a long period of time, the battery must be removed from the tool.
14. During and after use, the battery cartridge may take on heat which can cause burns or low temperature burns. Pay attention to the handling of hot battery cartridges.
15. Do not touch the terminal of the tool immediately after use as it may get hot enough to cause burns.
16. Do not allow chips, dust, or soil stuck into the terminals, holes, and grooves of the battery cartridge. It may cause heating, catching fire, burst and malfunction of the tool or battery cartridge, resulting in burns or personal injury.
17. Unless the tool supports the use near high-voltage electrical power lines, do not use the battery cartridge near high-voltage electrical power lines. It may result in a malfunction or breakdown of the tool or battery cartridge.
18. Keep the battery away from children.

SAVE THESE INSTRUCTIONS.

⚠ CAUTION: Only use genuine Makita batteries. Use of non-genuine Makita batteries, or batteries that have been altered, may result in the battery bursting causing fires, personal injury and damage. It will also void the Makita warranty for the Makita tool and charger.

Tips for maintaining maximum battery life

1. Charge the battery cartridge before completely discharged. Always stop tool operation and charge the battery cartridge when you notice less tool power.
2. Never recharge a fully charged battery cartridge. Overcharging shortens the battery service life.
3. Charge the battery cartridge with room temperature at 10 °C - 40 °C (50 °F - 104 °F). Let a hot battery cartridge cool down before charging it.
4. When not using the battery cartridge, remove it from the tool or the charger.
5. Charge the battery cartridge if you do not use it for a long period (more than six months).

FUNCTIONAL DESCRIPTION

CAUTION: Always be sure that the appliance is switched off and the battery cartridges are removed before adjusting or checking function on the appliance.

Installing or removing battery cartridge

CAUTION: Always switch off the appliance before installing or removing of the battery cartridge.

CAUTION: Hold the appliance and the battery cartridge firmly when installing or removing battery cartridge. Failure to hold the appliance and the battery cartridge firmly may cause them to slip off your hands and result in damage to the appliance and battery cartridge and a personal injury.

To install the battery cartridges, align the tongues on the battery cartridges with the grooves in the housing and slip them into place. Insert them all the way until they lock in place with a little click. If you can see the red indicators as shown in the figure, they are not locked completely.

To remove the battery cartridges, slide them out of the battery housing while pressing and holding the buttons in front of the cartridges.

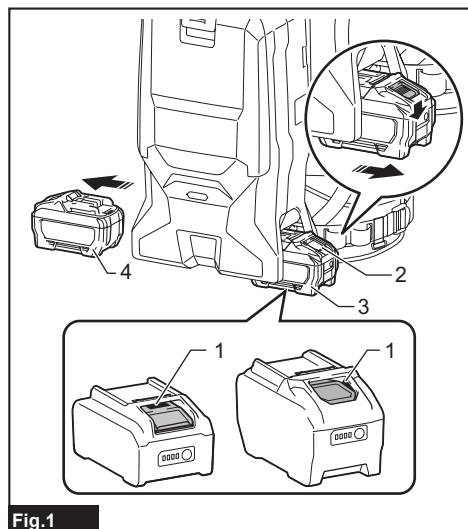

Fig.1

- 1. Red indicator 2. Button 3. Right battery cartridge
4. Left battery cartridge

CAUTION: Always install the battery cartridge fully until the red indicator cannot be seen. If not, it may accidentally fall out of the appliance, causing injury to you or someone around you.

CAUTION: Do not install the battery cartridge forcibly. If the cartridge does not slide in easily, it is not being inserted correctly.

The cleaner has double battery slots. You can choose with either double batteries or single battery according to your needs.

With double batteries

Continuous drive with two batteries allows longer runtime and more efficient cleaning. When the first battery is becoming empty, the cleaner automatically switches a power source, so it continues working with the second battery.

NOTE: The right battery slot (when facing the front of the cleaner) has priority over the left battery slot. The left battery slot will only be identified as a power source, either when no battery is installed in the right battery slot or the battery in the right battery slot becomes empty.

NOTE: You can remove the battery from the right battery slot and recharge it after the cleaner has switched its power source from the right battery slot to the left without ceasing operation. To give priority back to the right battery slot after installing a recharged battery, restart the cleaner.

NOTE: When the cleaner switches the power source from the first battery to the second, it may require a temporary halt in operations, causing a slight loss of suction. This is not malfunction so the cleaner recovers and resumes operations immediately after the pause.

With a single battery

Only one battery is required as a power source in either the right or left battery slot. The cleaner automatically determines which battery slot is available.

Indicating the remaining battery capacity

Press the check button on the battery cartridge to indicate the remaining battery capacity. The indicator lamps light up for a few seconds.

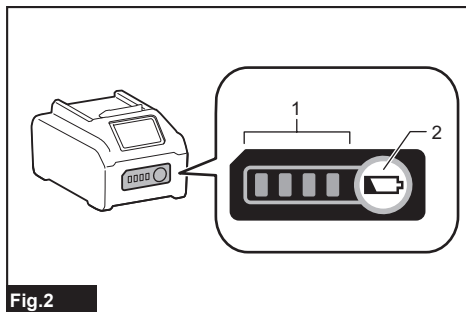

Fig.2

- 1. Indicator lamps 2. Check button

Indicator lamps			Remaining capacity
Lighted	Off	Blinking	
■	□	▧	75% to 100%
■ ■ ■ ■			
■ ■ ■ □			50% to 75%
■ ■ □ □			25% to 50%
■ □ □ □			0% to 25%
▧ □ □ □			Charge the battery.
■ ■ □ □			The battery may have malfunctioned.
□ □ ■ ■	↑ ↓		

NOTE: Depending on the conditions of use and the ambient temperature, the indication may differ slightly from the actual capacity.

NOTE: The first (far left) indicator lamp will blink when the battery protection system works.

Indicating the remaining battery capacity on the switch box

The remaining battery capacity can be checked on the switch box. Press the  button to indicate the remaining battery capacities.

"L" and "R" on the switch box correspond to the left and right battery cartridges, respectively. Follow the indication when you replace the battery cartridge.

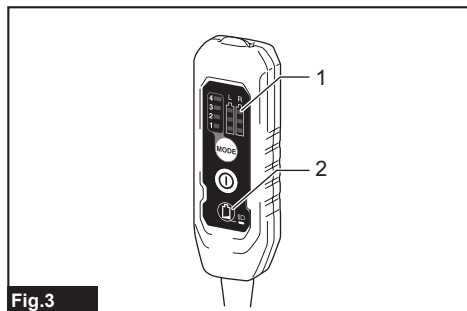



Fig.3

- 1. Battery indicator 2. Battery check / LED light button 

Battery indicator status			Remaining battery capacity
On	Off	Blinking	
■	□	▧	50% to 100%
	▧		
	▧		20% to 50%
	▧		0% to 20%
	▧		Charge the battery

Appliance / battery protection system

The appliance is equipped with appliance / battery protection system. This system automatically cuts off power to the motor to extend appliance and battery life. In this situation, the battery indicator lights up as following table.

Battery indicator status			Status
On	Off	Blinking	
		▧	Overload protection (battery) / Overheat protection (battery) / Overdischarge protection
		▧	Overheat protection (appliance)

The appliance and the LED light will automatically stop during operation if the appliance or battery is placed under one of the following conditions:

Overload protection

When the appliance / battery is operated in a manner that causes it to draw an abnormally high current, the appliance automatically stops. In this situation, turn the appliance off and stop the application that caused the appliance to become overloaded. Then turn the appliance on to restart.

Overheat protection

When the appliance / battery is overheated, the appliance stops automatically. In this situation, let the appliance / battery cool down before turning the appliance on again.

Overdischarge protection

When the battery capacity becomes low, the appliance stops automatically. If the product does not operate even when the switches are operated, remove the batteries from the appliance and charge the batteries.

Protections against other causes

Protection system is also designed for other causes that could damage the appliance and allows the appliance to stop automatically. Take all the following steps to clear the causes, when the appliance has been brought to a temporary halt or stop in operation.

1. Turn the appliance off, and then turn it on again to restart.
2. Charge the battery(ies) or replace it/them with recharged battery(ies).
3. Let the appliance and battery(ies) cool down.

If no improvement can be found by restoring protection system, then contact your local Makita Service Center.

Switch box position

The switch box can be hooked on either side of the lower belt. Arrange the cord so that the switch box comes to your desired side. To prevent the cord from being damaged, pass the cord through the groove as illustrated.

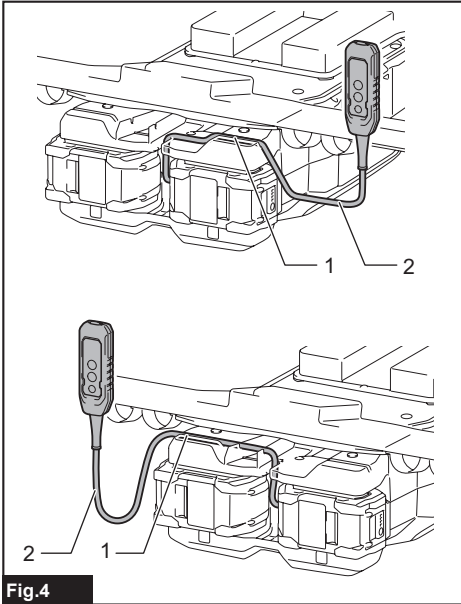

Fig.4

- 1. Groove 2. Cord

Adjusting belts

The tightness of the shoulder belts, upper and lower belts can be adjusted. Put your arms through the shoulder belts first then fasten the lower and upper belts. To tighten, pull the end of the strap as illustrated. To loosen, pull up the end of the fastener.

Lower belt

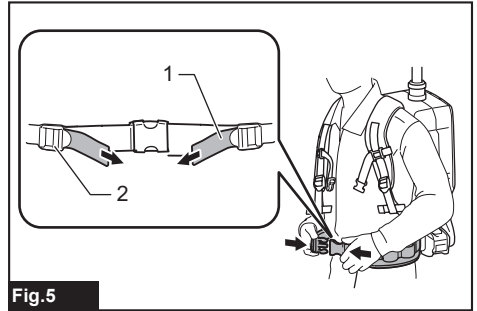

Fig.5

- 1. Strap 2. Fastener

Shoulder belts

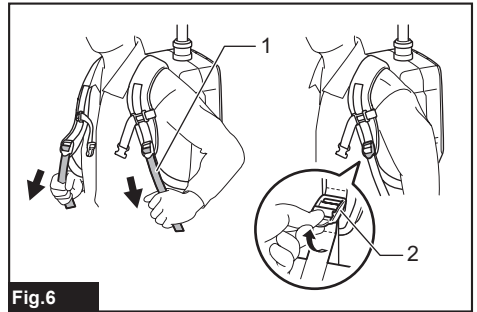

Fig.6

- 1. Strap 2. Fastener

Upper belt

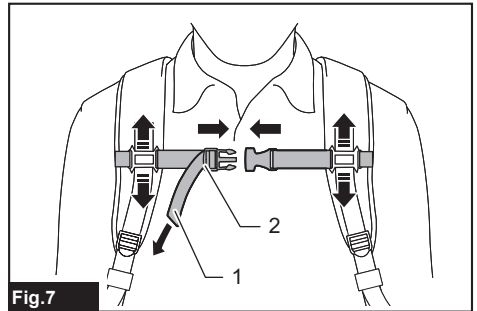

Fig.7

- 1. Strap 2. Fastener

Carrying hook

Always grab the carrying hook when handling the vacuum cleaner body.

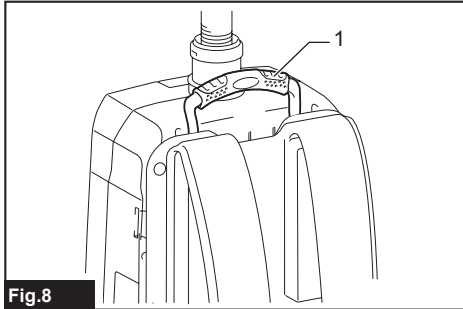

Fig.8

► 1. Carrying hook

Switch action

To start the cleaner, simply press **ⓘ** button. To switch off, press **ⓘ** button again. You can change the suction power of the cleaner in four steps by pressing **MODE** button. Each press on this button repeats the 1 to 4 mode in a cycle.

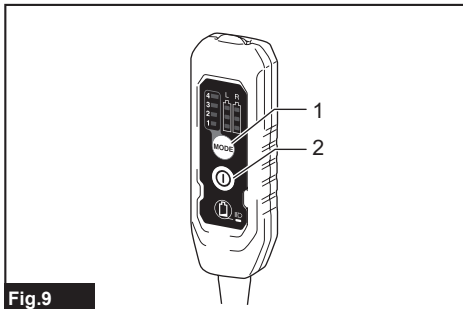

Fig.9

► 1. Suction power change button **MODE** 2. ON/OFF button **ⓘ**

Level	Indication	Mode
1		Quiet mode
2		Normal speed mode
3		High speed mode
4		Max speed mode

NOTE: You can change the suction power before turning on the cleaner.

NOTE: The cleaner starts the operation with the same suction power as the last operation.

NOTE: If you remove the battery immediately after turning off the appliance, while the motor is rotating, the cleaner may not start the operation with the same suction power as the last operation.

LED light

LED light is installed in the head of the switch box to ease the operations in dark places. Press and hold **ⓘ** button to turn the light on. To turn off, press and hold **ⓘ** button again.

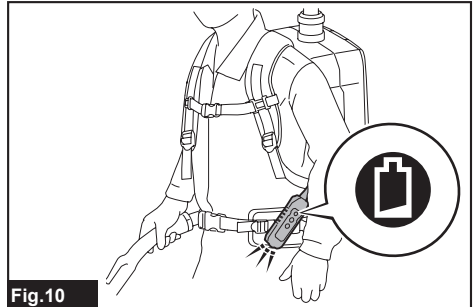

Fig.10

CAUTION: Do not look in the light or see the source of light directly. Never aim the light to other people's eyes.

NOTE: The LED light is automatically turned off when the vacuum cleaner is not operated for more than 10 minutes.

Hose band

Hose band can be used for holding the hose or flexible rubber nozzle.

To secure the hose to the vacuum cleaner body, pass the hose band through the slot on the body. You can attach the hose band on either side.

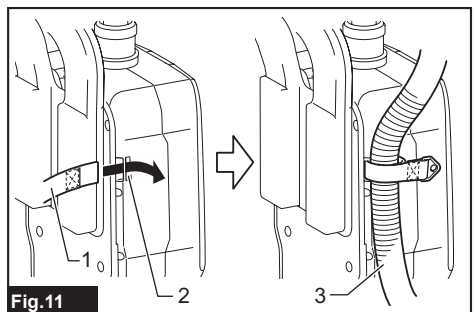

Fig.11

► 1. Hose band 2. Slot 3. Hose

The loops on the lower belt can be used for carrying nozzles as illustrated.

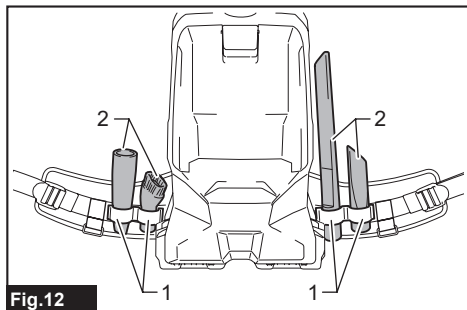

Fig.12

► 1. Loop 2. Nozzle

Hose hook

When you suspend the operation, the hook on the bent pipe assembly can be used for hanging the wand on the hanging part of the lower belt.

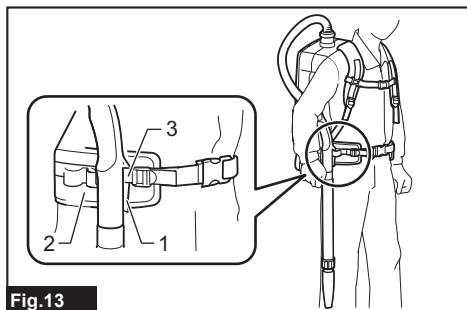

Fig.13

► 1. Hook 2. Lower belt 3. Hanging part

ASSEMBLY

CAUTION: Always be sure that the appliance is switched off and the battery cartridge is removed before carrying out any work on the appliance.

Assembling hose

Insert the hose cuff into the vacuum cleaner body and turn it clockwise.

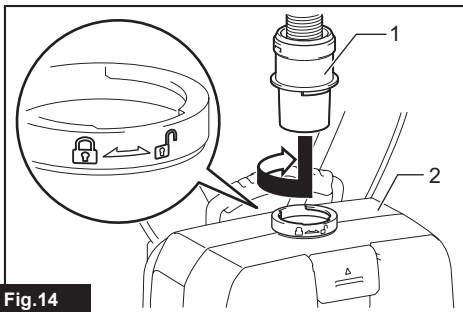

Fig.14

► 1. Hose cuff 2. Vacuum cleaner body

Using as a cleaner

Attaching bent pipe assembly

Optional accessory

NOTE: You don't need to perform this procedure if your model comes with the bent pipe assembly attached to the hose.

NOTE: There are two types of bent pipe assembly; the one for slide-type extension wand and the one for ring-type extension wand. If you prepare the bent pipe assembly, choose the one for your desired extension wand type.

The bent pipe assembly is used for connecting the extension wand or nozzle for vacuum cleaning to this product. If you want to use this product as the vacuum cleaner, attach the bent pipe assembly to the hose.

For the screw-in type bent pipe assembly

To attach, unscrew the front cuff from the hose and fasten the sleeve of bent pipe assembly onto the hose. To remove, loosen the sleeve of bent pipe assembly from the hose.

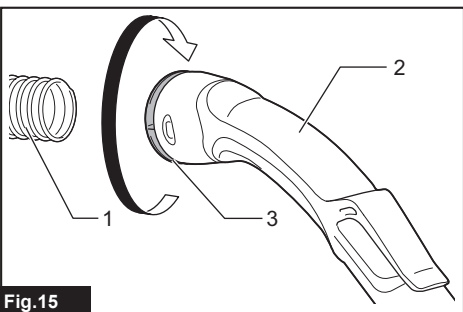

Fig.15

► 1. Hose 2. Bent pipe assembly 3. Sleeve

For the snap-on type bent pipe assembly

To attach, insert the hose end into the bent pipe assembly. Make sure that the tabs on the hose end snap into the holes on the bent pipe assembly.

To remove, pull the bent pipe assembly while pressing both of the tabs on the hose end.

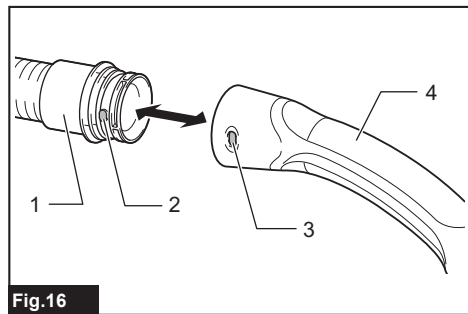

Fig.16

► 1. Hose end 2. Tab 3. Hole 4. Bent pipe assembly

Assembling nozzle and wand

Optional accessory

NOTE: The type of the nozzle and wand included in the product varies depending on countries. In some countries, the nozzle and wand are not included.

1. Twist and insert the nozzle to the extension wand.

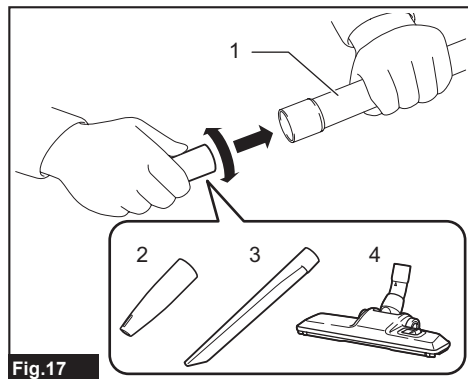

Fig.17

► 1. Extension wand 2. Flexible rubber nozzle
3. Corner nozzle 4. Floor/carpet switching t-nozzle

When using floor/carpet switching t-nozzle, you can change the mode depending on the place.

— Floor mode: suitable for a smooth place such as a hard floor

— Carpet mode: suitable for a shaggy place such as a carpet or a rug

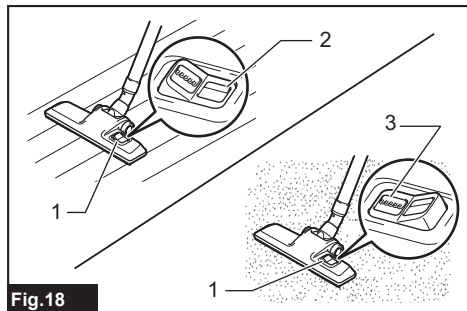

Fig.18

► 1. Mode switching button 2. Floor mode 3. Carpet mode

NOTE: By twisting the nozzle while inserting, the nozzle can be attached to the extension wand securely.

NOTE: For the model with $\varnothing 38$ mm hose and front cuff 38, attach the supplied nozzle to the aluminum bent pipe / aluminum straight pipe.

2. Follow the procedures below, depending on the type of the extension wand:

NOTE: The slide-type extension wand and the ring-type extension wand are not compatible with each other. If you want to change the slide-type extension wand to the ring-type extension wand or vice versa, change the bent pipe assembly also.

For the slide-type extension wand

Shoulder the vacuum cleaner body then insert the extension wand into the bent pipe assembly until it clicks. To disconnect, extract the extension wand with pressing the button.

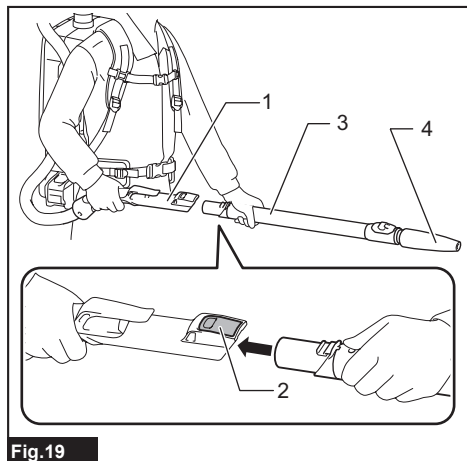

Fig.19

► 1. Bent pipe assembly 2. Button 3. Slide-type extension wand 4. Flexible rubber nozzle

The length of the wand can be adjusted.
 With pressing the slide button, adjust the wand length.
 The length is locked when releasing the slide button.

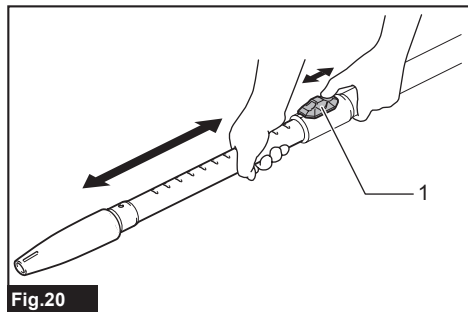

Fig.20

► 1. Slide button

For the ring-type extension wand

Shoulder the vacuum cleaner body then twist and insert the extension wand into the bent pipe assembly. To disconnect, twist and extract it.

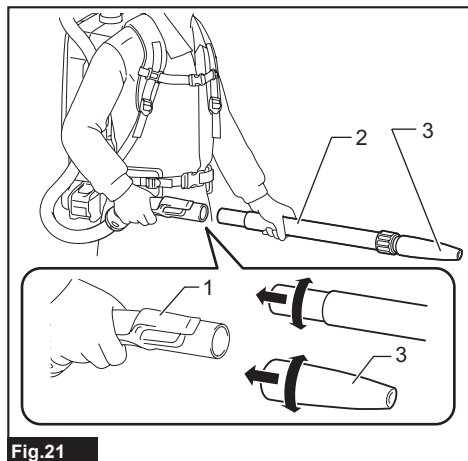

Fig.21

► 1. Bent pipe assembly 2. Ring-type extension wand
 3. Flexible rubber nozzle

NOTE: The flexible rubber nozzle can be attached to the bent pipe assembly without pipe lock directly.

The length of the wand can be adjusted.
 Loosen the ring on the wand and adjust the wand length. Tighten the ring at your desired length.

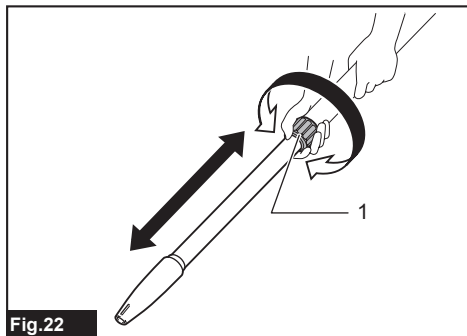

Fig.22

► 1. Ring

For the aluminum bent pipe / aluminum straight pipe

(Only for the model with $\varnothing 38$ mm hose and front cuff 38)
 Shoulder the vacuum cleaner body then twist and insert the pipe into the front cuff. To disconnect, twist and extract it.

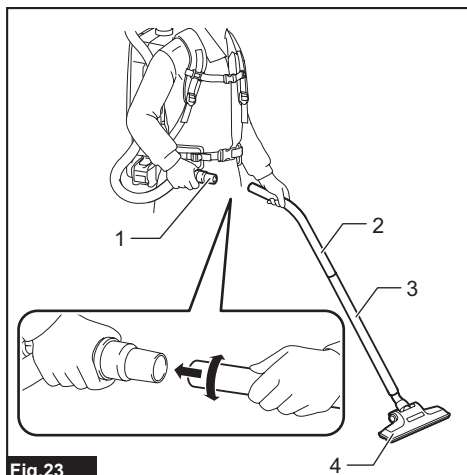

Fig.23

► 1. Front cuff 38 2. Aluminum bent pipe 3. Aluminum straight pipe 4. Nozzle

For the two aluminum straight pipes

Shoulder the vacuum cleaner body then twist and insert the pipes. To disconnect, twist and extract it.

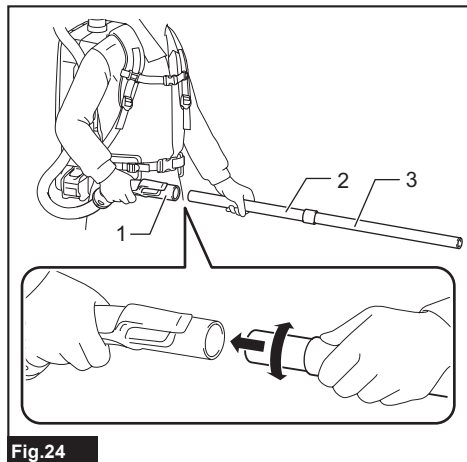

Fig.24



- ▶ 1. Bent pipe assembly 2. Aluminum straight pipe 1
- 3. Aluminum straight pipe 2



Connecting the tool

NOTE: If the bent pipe assembly is attached to the hose, remove it beforehand.

To connect a tool to the cleaner, the dedicated hose and/or additional parts are required. Depending on your cleaner model, you need to replace the hose and/or prepare additional parts.

Refer to the following table for details.

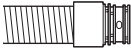
Supplied hose diameter	Hose end type	Action
ø28 mm	 without part	Attach the front cuff.
	 with snap-on part	Replace the hose end (snap-on part) with the front cuff. The hose end can be removed by turning it counterclockwise.
ø32 mm	 with snap-on part	Replace the hose with the one for dust extraction (ø28 mm, with front cuff).

Supplied hose diameter	Hose end type	Action
ø38 mm	 with snap-on part	Replace the hose with the one for dust extraction (ø28 mm, with front cuff).
	 with front cuff 38	Attach the joint 22-38 or the front cuff 24.

NOTE: Always use a suitable front cuff. When using the front cuff 24, attach it to the front cuff 22 that is connected to the hose.

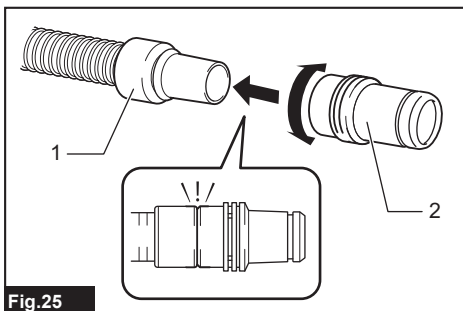

Fig.25

- ▶ 1. Front cuff 22 2. Front cuff 24

When using ø28 mm dust extraction hose

1. Attach the front cuff to the hose for dust extraction. When connecting the front cuff, make sure that it is securely screwed on the hose.
2. Connect the front cuff to the tool's extraction outlet.

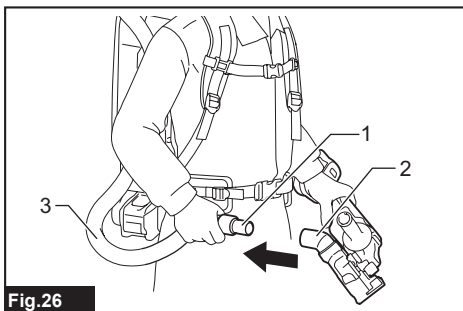

Fig.26

- ▶ 1. Front cuff 2. Extraction outlet 3. Hose

The front cuff can be detached by turning it counterclockwise while holding the hose.

When using ø38 mm hose with front cuff 38

1. Twist and insert the joint or the front cuff to the inlet part on the hose, depending on the tool that you are going to connect.
2. Connect the front cuff to the tool's extraction outlet.

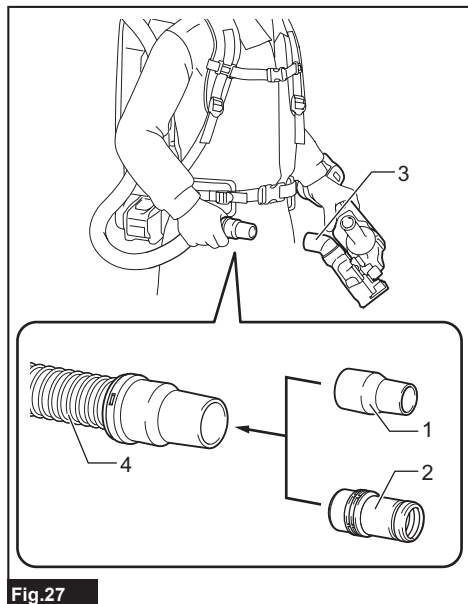

Fig.27

- 1. Joint 2. Front cuff 3. Extraction outlet 4. Hose

To remove the joint and the front cuff, follow the installation procedures in reverse.

Installing filter bag / dust bag

Optional accessory

CAUTION: Do not use a damaged filter bag. Always use the vacuum cleaner with the filter bag properly installed. Otherwise the vacuumed dust or particles may be exhausted from the cleaner and they may cause respiratory disease to the operator.

Install either dust bag or filter bag before using cleaner.

- Dust bag is usable many times repeatedly by cleaning it out.
- Filter bag is a throw-away type. Throw away the entire filter bag without emptying when it has become full.

NOTICE: When the filter bag is already full, replace with new one. When the dust bag is already full, empty it. Continuous use with the filter bag/dust bag full results in reduced suction power.

NOTICE: To prevent dust from getting into the motor:

- Make sure that the filter bag/dust bag is installed before use.
- Do not use a broken or ripped bag.

Otherwise the motor may be broken.

NOTICE: Do not fold the cardboard at its opening when installing the filter bag/dust bag.

NOTICE: The filter bag/dust bag for the cleaner is an important component for maintaining the appliance performance. Using non-genuine filter bag/dust bag may cause smoke or ignition.

NOTE: When the filter bag/dust bag is not installed in the cleaner, the front cover does not close completely.

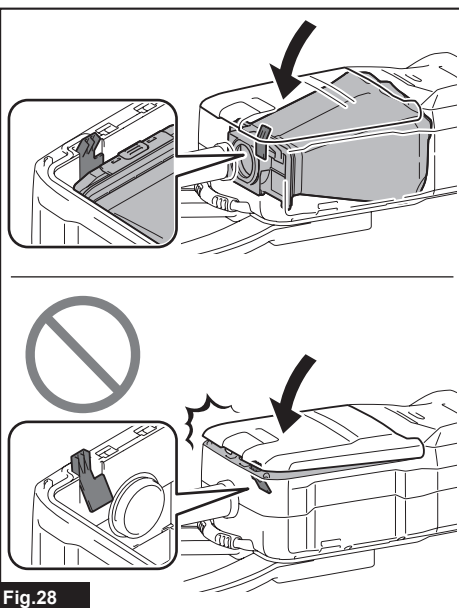

Fig.28

1. Unlock the lever and open the front cover.

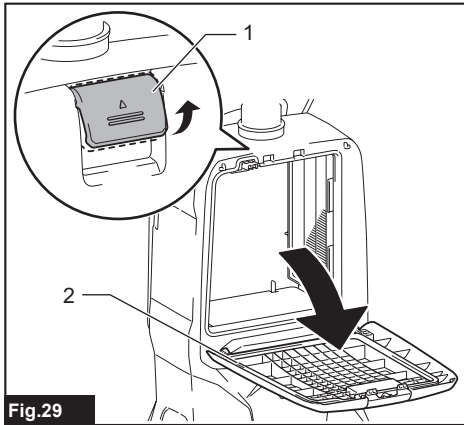

Fig.29

- ▶ 1. Lever 2. Front cover

2. Insert the filter bag into the slit on the upper side of the room as illustrated.

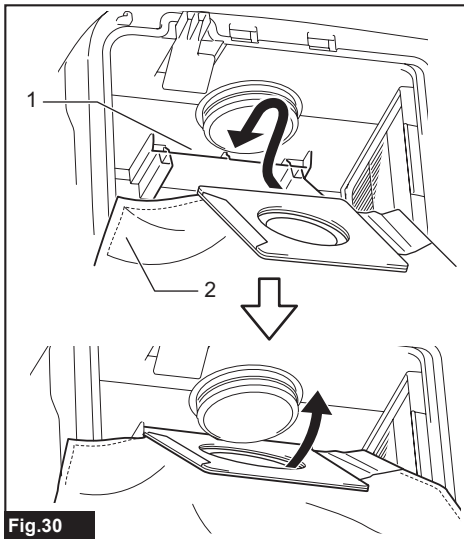

Fig.30

- ▶ 1. Slit 2. Filter bag

When using the dust bag, insert the brim of the dust bag into the slit.

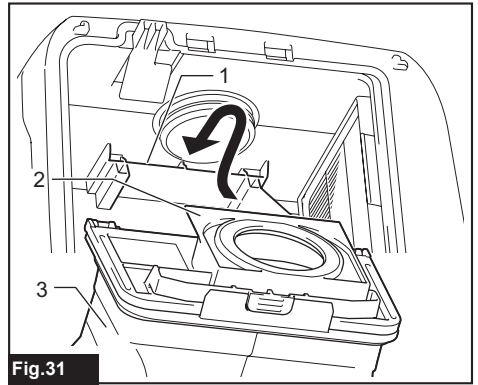

Fig.31

- ▶ 1. Slit 2. Brim 3. Dust bag

3. Align the hole of the filter bag with the hose cuff and push the cardboard portion to the end. Make sure that the rubber ring on the filter bag goes over the rim on the hose cuff.

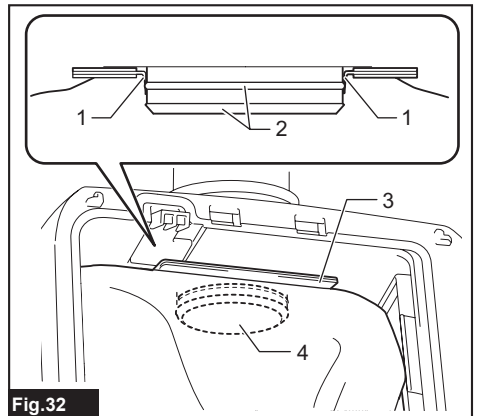

Fig.32

- ▶ 1. Rubber ring on the filter bag 2. Rim on the hose cuff 3. Cardboard portion of the filter bag 4. Hose cuff

4. Lock the front cover certainly.

CAUTION: Be careful not to pinch your fingers when hooking the latch, and when closing the front cover.

Harness cover

Optional accessory

When using the harness cover, follow the procedure below to attach it.

NOTE: When installing the harness cover, do not mistake the front and back of the harness cover.

NOTE: The harness cover is washable. Follow the washing instructions on the tag.

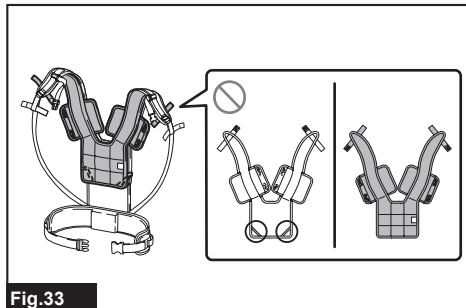

1. Spread the harness cover on the harness.

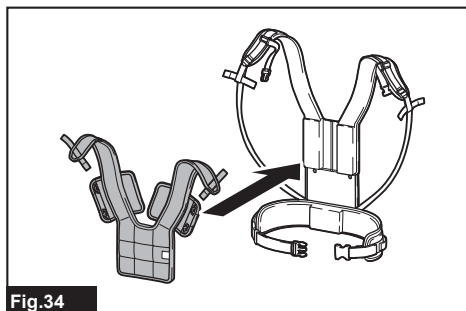

2. Secure the harness shoulder straps with the hook and loop fasteners of the harness cover. Hook the band of the harness cover on the harness.

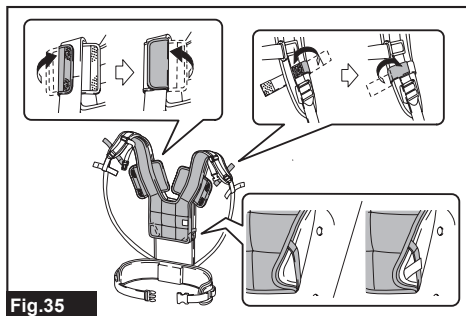

OPERATION

⚠WARNING: Operators shall be adequately instructed on the use of the vacuum cleaner.

⚠WARNING: This vacuum cleaner is not suitable for picking up hazardous dust.

⚠CAUTION: This cleaner is for dry use only.

⚠CAUTION: During operation, be conscious of the vacuum cleaner on your back. You may lose your balance if the vacuum cleaner body bumps against a wall or the hose is hooked by an obstacle.

1. Shoulder the vacuum cleaner body and fasten upper and lower belts. Adjust the tightness as necessary.

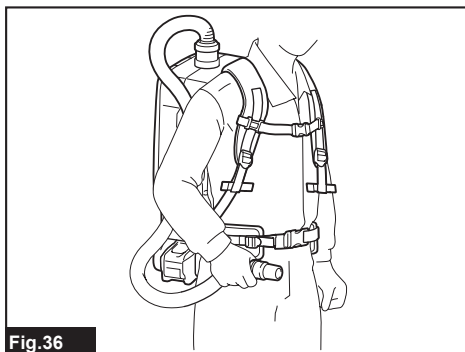

2. Press **⏻** button to start vacuuming. If you want to change the suction power, press **⏻** button until the desired suction power is selected. Press **⏻** button to stop.

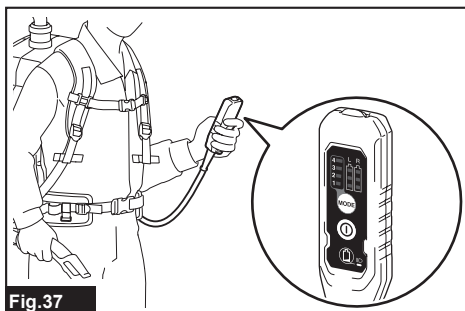

During the operation, hook the switch box on the D-ring or the hanging part of the lower belt. The hook can be slanted for lighting forward when hooked on the hanging part.

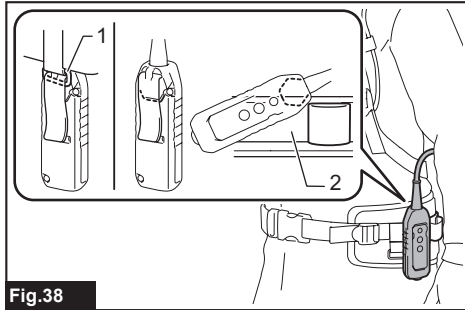

Fig.38

► 1. D-ring 2. Hanging part

3. Replace the filter bag when it becomes full. Open the front cover and take out the filter bag. Pull the strip on the side of the opening to shut the filter bag and dispose of the filter bag in whole.

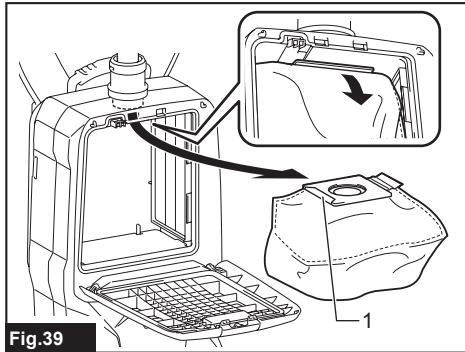

Fig.39

► 1. Strip

When using a dust bag, take out the dust bag and dispose of the dust by releasing the latch.

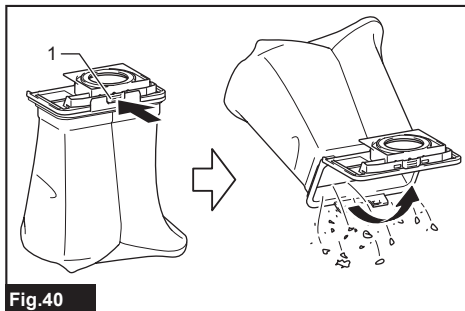

Fig.40

► 1. Latch

NOTICE: Do not put filter bag/dust bag or other heavy objects on the front cover. The appliance may fall down.

NOTICE: Periodically check the filter bag whether the filter is full or not. Continuous use with the filter bag full results in reduced suction power.

NOTICE: Do not use a used filter bag. The filter bag is designed for single use. Using filter bag repeatedly may cause clogging of the filter and results in damage to the cleaner. If you want to use the bag repeatedly, use a dust bag.

MAINTENANCE

CAUTION: Always be sure that the appliance is switched off and the battery cartridge is removed before attempting to perform inspection or maintenance.

NOTICE: Never use gasoline, benzene, thinner, alcohol or the like. Discoloration, deformation or cracks may result.

To maintain product SAFETY and RELIABILITY, repairs, any other maintenance or adjustment should be performed by Makita Authorized or Factory Service Centers, always using Makita replacement parts.

Cleaning the HEPA filter

CAUTION: Do not use the vacuum cleaner without a filter or continue to use dirty or damaged filter. Vacuumed dust or particles may be exhausted from the cleaner and they may cause respiratory disease to the operator.

NOTICE: To keep optimum suction power and clean exhaust, clean the filter periodically. If enough suction power is not obtained even after the cleaning, replace the filter with new one.

NOTICE: To prevent the filter from being damaged, do not use following tools and similar items for cleaning:

- Air duster
- High pressure washer
- Tools made of hard materials such as a wire brush

1. Open the front cover and take out the filter bag/ dust bag. Release the hook on the filter and remove it from the vacuum cleaner body.

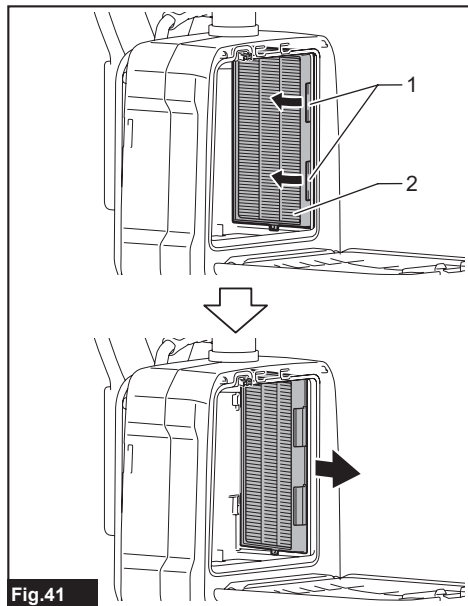

Fig.41

► 1. Hook 2. HEPA filter

2. Beat the dust off from the filter. The filter can be washed with water. Rinse away the dust and particles on the filter every 1 or 2 month. After that, dry the filter completely in a shaded and well-ventilated place to prevent unpleasant odor or malfunctions.

3. To install the filter, insert the side without the hooks into the groove then push in the filter until the hooks are secured with a click.

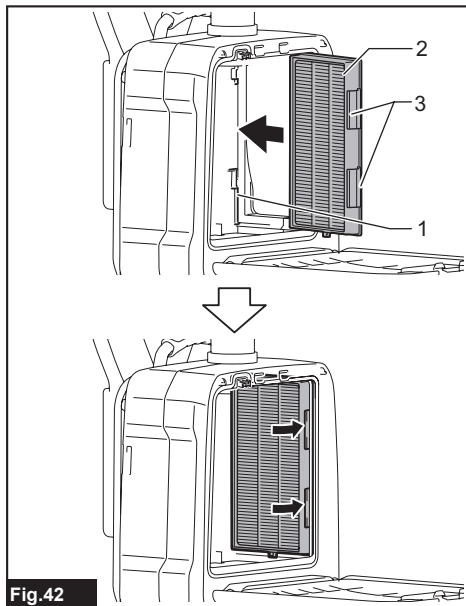

Fig.42

► 1. Groove 2. HEPA filter 3. Hook

Cleaning the sponge filter

CAUTION: After cleaning the sponge filters, be sure to install them to the vacuum cleaner. If washed in water, dry them up thoroughly before installing. Insufficiently dried sponge filters may shorten the service life of the motor.

Sponge filters underneath the HEPA filter prevent dust from getting into the motor.

1. Remove the sponge filters from the vacuum cleaner.

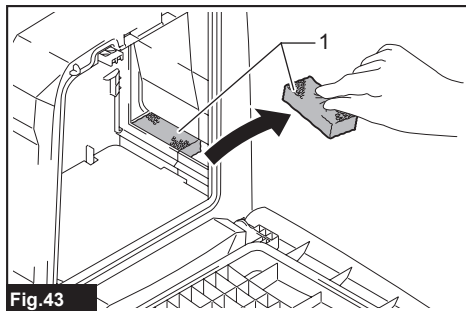

Fig.43

► 1. Sponge filter

- Wipe and shake dust off the sponge filters by hand. When the sponge filters are clogged, wash them in soapy water.

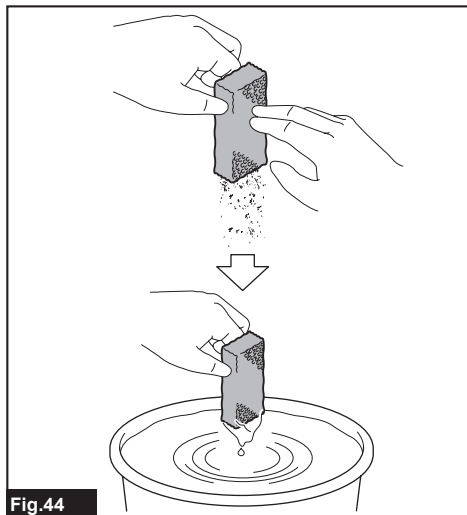

Fig.44

- Install the sponge filters in their original position.

Cleaning the dust bag

Regularly clean the dust bag with soap and water. Turn the dust bag inside out and remove the sticky dust. Wash lightly by hand and rinse well with water. Dry completely before installing to the vacuum cleaner.

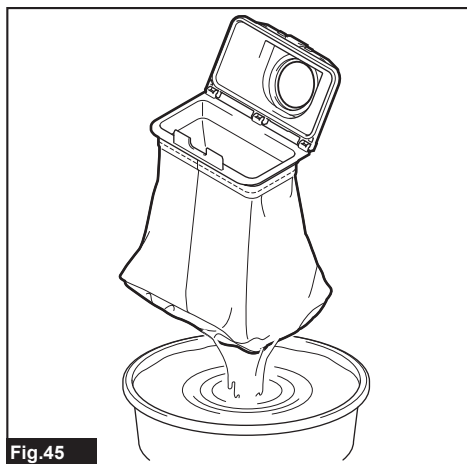

Fig.45

NOTICE: Wet dust bag lowers the vacuuming performance as well as the life of the motor.

Cleaning the clog

When cleaning the clog, remove the hose or the extension wand, or the bent pipe assembly to check inside. Refer to the section for attaching bent pipe assembly.

Cleaning the room for filter bag/dust bag

This appliance is equipped with a dust beating system. As you walk while carrying the cleaner, springs underneath the board vibrate the board and shake the dust off the filter bag/dust bag. When cleaning the room for filter bag/dust bag, remove and wipe the board inside.

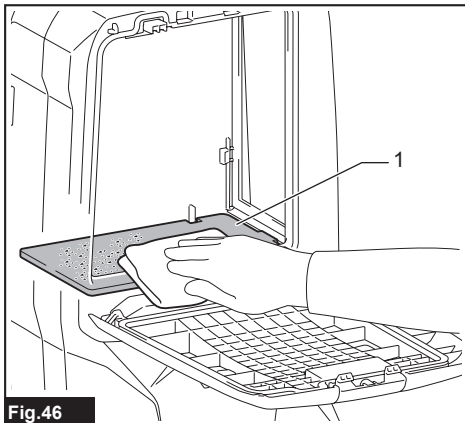

Fig.46

- 1. Board

Removing the board

- Remove the HEPA filter. Refer to the section for cleaning the HEPA filter for how to remove.
- Push down the board, and slide it to left until the board touches the wall.
- Lift the right side of the board up and take it out.

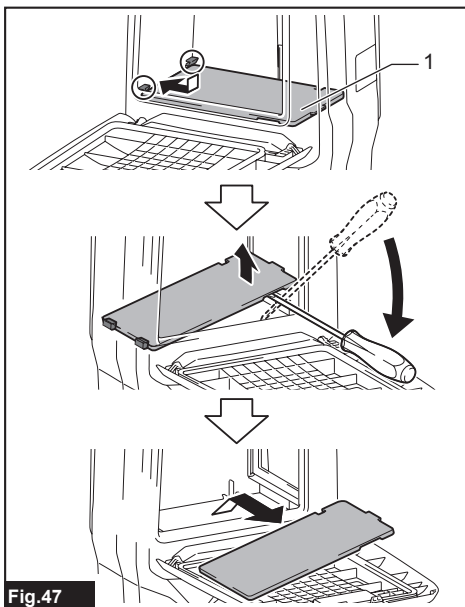

Fig.47

- 1. Board

The board is supported by three springs.
If the springs came off from the projections, reattach them as illustrated.

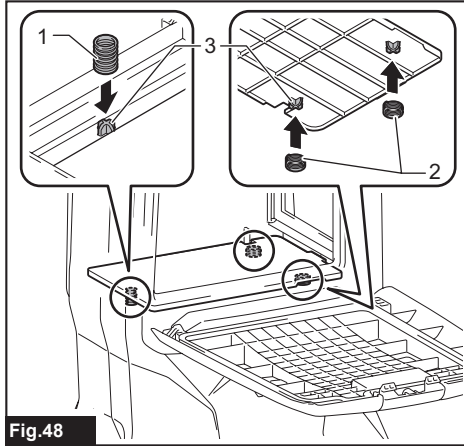

Fig.48

▶ 1. Long spring 2. Short spring 3. Projection

NOTE: Attach the springs securely so that the springs touch the root of the projections.

Attaching the board

1. Insert the straight side of the board into the catches in the lower left side of the room.
2. Put the right side of the board in place.

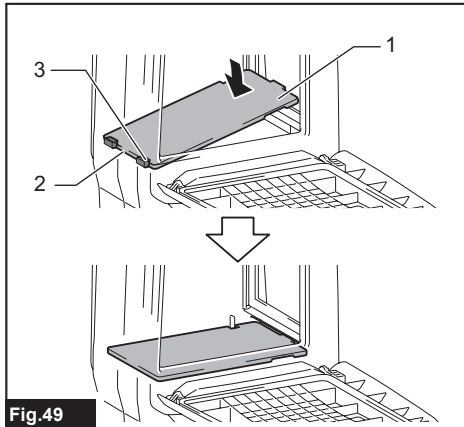

Fig.49

▶ 1. Board 2. Straight side 3. Catch

CYCLONE ATTACHMENT

Optional accessory

NOTE: When using the cyclone attachment with this appliance, the bent pipe is also required.

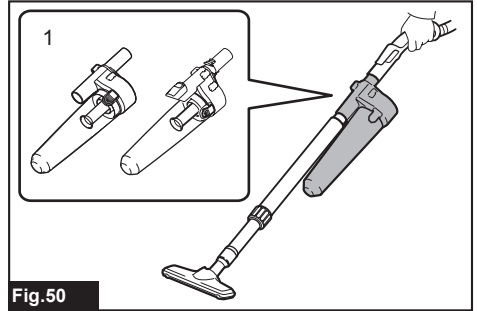

Fig.50

▶ 1. Cyclone attachment

About the cyclone attachment

Using the cleaner with the cyclone attachment installed reduces the amount of dust that enters the dust bag, which helps to prevent the suction force from weakening. In addition, cleaning after use is also simple.

CAUTION: Always be sure that the tool is switched off and the battery cartridge is removed before carrying out any work on the tool. If the battery cartridge is left inserted, the cleaner may start unexpectedly and result in injury.

CAUTION: Clean the mesh filter of the cyclone attachment and the dust bag of the cleaner unit when they become clogged. Continued use in the clogged condition may result in heating or smoke.

NOTICE: When the cyclone attachment is attached, do not use the cyclone attachment in the horizontal or upward facing condition. Doing so may cause the mesh filter to become clogged.

NOTICE: Always use the cleaner with the dust bag installed, even when using the cyclone attachment. Using the cleaner without the dust bag installed may result in a motor malfunction.

NOTE: Check that the cyclone attachment, cleaner, and straight pipe are locked properly before use.

NOTE: Empty the dust case of the cyclone attachment and the dust bag of the cleaner when dust has accumulated. Continued use will result in weakened suction force.

NOTE: You can use the cyclone attachment with or without lock function.

NOTE: To install or remove the cyclone attachment, refer to the section "Using as a cleaner".

Disposing of dust

When dust has accumulated up to the full line of the dust case, follow the procedure below and dispose of the dust.

1. Hold the dust case firmly, press and hold the two buttons, and remove the dust case.

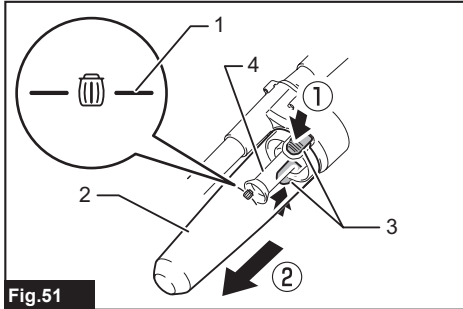

Fig.51

1. Full line 2. Dust case 3. Button (two locations) 4. Mesh filter
2. Dispose of the dust inside the dust case and remove any dust and powder adhered to the surface of the mesh filter.
3. Insert the dust case all the way until the two buttons lock with a click.

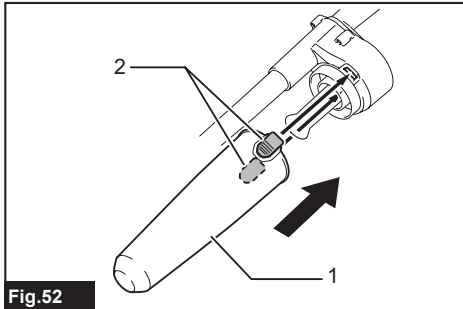

Fig.52

1. Dust case 2. Button (two locations)

NOTE: Check that the cyclone attachment, cleaner, and straight pipe are locked properly before restarting operation.

NOTE: If the suction force does not recover even after disposing of the dust and cleaning the mesh filter, check whether dust has accumulated in the dust bag of the cleaner or clogging has occurred.

Cleaning

When the dust case becomes dirty or the mesh filter is clogged, remove and wash them with water. (Refer to "Disposing of dust" for the removal procedure.)

Dry the parts thoroughly before reinstallation and use.

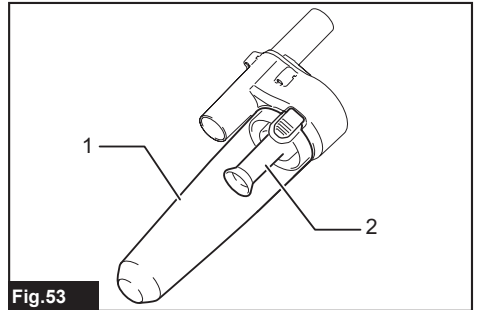

Fig.53

1. Dust case 2. Mesh filter

When the mesh filter gets dirty badly, clean it in the following procedures.

1. Turn the mesh filter counterclockwise and remove it while the hooks are unlocked.

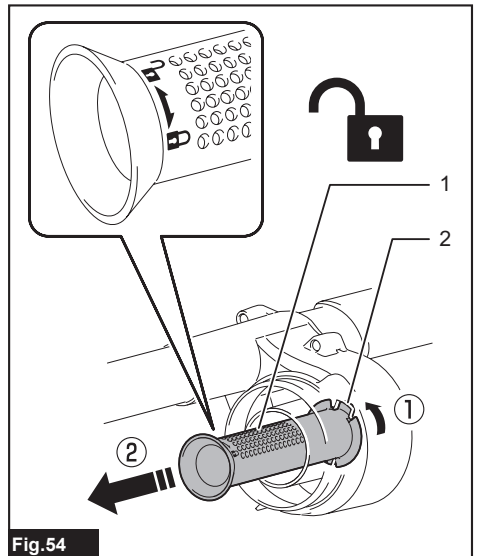

Fig.54

1. Mesh filter 2. Hook

2. Remove the dust on the mesh filter and then wash it with water. After that, dry it thoroughly.

3. Insert the mesh filter into the base while the hooks are aligned with the ports. Turn the mesh filter clockwise until the hooks are locked with a click. Make sure that the mesh filter is installed securely.

- Pipe
- Harness cover
- Cyclone attachment
- Makita genuine battery and charger

NOTE: Some items in the list may be included in the tool package as standard accessories. They may differ from country to country.

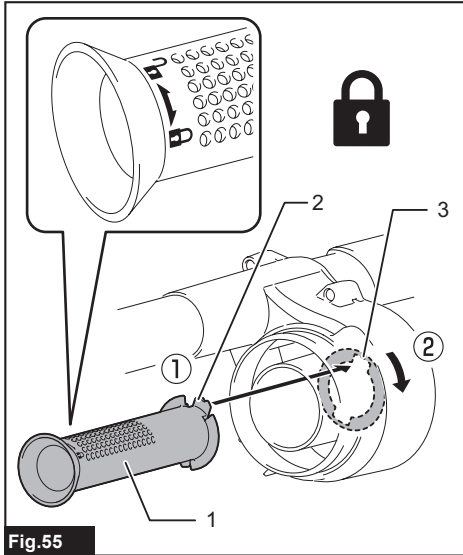

Fig.55

► 1. Mesh filter 2. Hook 3. Port

OPTIONAL ACCESSORIES

⚠ CAUTION: These accessories or attachments are recommended for use with your Makita product specified in this manual. The use of any other accessories or attachments might present a risk of injury to persons. Only use accessory or attachment for its stated purpose.

Some accessories may not be installed according to the combination of parts.

If you need any assistance for more details regarding these accessories, ask your local Makita Service Center.

- Hose (for vacuum cleaner type)
- Hose (for dust extraction type)
- Extension wand
- Flexible rubber nozzle
- T-shape nozzle
- Seat nozzle
- Corner nozzle
- Shelf brush
- Round brush
- Bent pipe assembly
- Filter bag
- Dust bag
- Front cuff
- HEPA filter

Makita Europe N.V.

Jan-Baptist Vinkstraat 2, 3070 Kortenberg, Belgium

Makita Corporation

3-11-8, Sumiyoshi-cho, Anjo, Aichi 446-8502 Japan

www.makita.com



885A49-221 EN 20230731
