

INSTRUCTION MANUAL

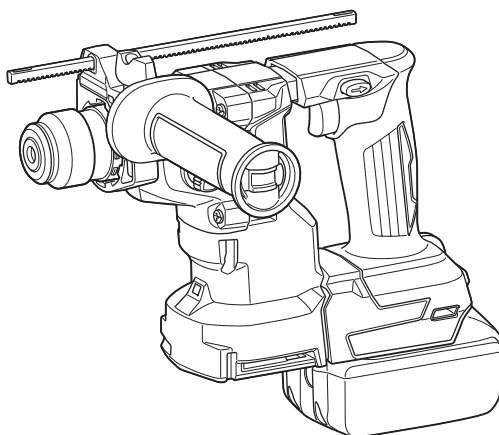

# Cordless Rotary Hammer

## DHR183



Read before use.

# SPECIFICATIONS

<b>Model:</b>		<b>DHR183</b>
Drilling capacities	Concrete	18 mm
	Steel	13 mm
	Wood	24 mm
No load speed		0 - 1,100 min <sup>-1</sup>
Blows per minute		0 - 5,000 min <sup>-1</sup>
Overall length (with BL1860B)		288 mm
Rated voltage		D.C. 18 V
Net weight		2.1 - 2.9 kg

## Optional accessory

<b>Model:</b>		<b>DX16</b>
Suction performance		0.24 l/min
Operating stroke		Up to 105 mm
Suitable drill bit		Up to 165 mm
Net weight		0.77 kg

- Due to our continuing program of research and development, the specifications herein are subject to change without notice.
- Specifications may differ from country to country.
- The weight may differ depending on the attachment(s), including the battery cartridge. The lightest and heaviest combinations, according to EPTA-Procedure 01/2014, are shown in the table.

## Applicable battery cartridge and charger

Battery cartridge	BL1815N / BL1820B / BL1830B / BL1840B / BL1850B / BL1860B
Charger	DC18RC / DC18RD / DC18RE / DC18SD / DC18SE / DC18SF / DC18SH / DC18WC

- Some of the battery cartridges and chargers listed above may not be available depending on your region of residence.

**⚠ WARNING: Only use the battery cartridges and chargers listed above.** Use of any other battery cartridges and chargers may cause injury and/or fire.

## Recommended cord connected power source

Portable power pack	PDC01
---------------------	-------

- The cord connected power source(s) listed above may not be available depending on your region of residence.
- Before using the cord connected power source, read instruction and cautionary markings on them.

## Symbols

The followings show the symbols which may be used for the equipment. Be sure that you understand their meaning before use.



Read instruction manual.



Only for EU countries  
 Due to the presence of hazardous components in the equipment, waste electrical and electronic equipment, accumulators and batteries may have a negative impact on the environment and human health. Do not dispose of electrical and electronic appliances or batteries with household waste! In accordance with the European Directive on waste electrical and electronic equipment and on accumulators and batteries and waste accumulators and batteries, as well as their adaptation to national law, waste electrical equipment, batteries and accumulators should be stored separately and delivered to a separate collection point for municipal waste, operating in accordance with the regulations on environmental protection. This is indicated by the symbol of the crossed-out wheeled bin placed on the equipment.

## Intended use

The tool is intended for hammer drilling and drilling in brick, concrete and stone.  
It is also suitable for drilling without impact in wood, metal, ceramic and plastic.

## Noise

The typical A-weighted noise level determined according to EN62841-2-6:

### Model DHR183

Sound pressure level ( $L_{pA}$ ): 90 dB (A)  
Sound power level ( $L_{WA}$ ): 101 dB (A)  
Uncertainty (K): 3 dB (A)

### Model DHR183 with DX16

Sound pressure level ( $L_{pA}$ ): 90 dB (A)  
Sound power level ( $L_{WA}$ ): 101 dB (A)  
Uncertainty (K): 3 dB (A)

**NOTE:** The declared noise emission value(s) has been measured in accordance with a standard test method and may be used for comparing one tool with another.

**NOTE:** The declared noise emission value(s) may also be used in a preliminary assessment of exposure.

**⚠ WARNING:** Wear ear protection.

**⚠ WARNING:** The noise emission during actual use of the power tool can differ from the declared value(s) depending on the ways in which the tool is used especially what kind of workpiece is processed.

**⚠ WARNING:** Be sure to identify safety measures to protect the operator that are based on an estimation of exposure in the actual conditions of use (taking account of all parts of the operating cycle such as the times when the tool is switched off and when it is running idle in addition to the trigger time).

## Vibration

The following table shows the vibration total value (tri-axial vector sum) determined according to applicable standard.

Work mode	Vibration emission	Uncertainty (K)	Applicable standard / Test condition
Hammer drilling into concrete ( $a_{h, HD}$ )	7.5 m/s <sup>2</sup>	1.5 m/s <sup>2</sup>	EN62841-2-6
	7.5 m/s <sup>2</sup>	1.5 m/s <sup>2</sup>	Recommended practical operation*
Hammer drilling into concrete with DX16 ( $a_{h, HD}$ )	7.6 m/s <sup>2</sup>	1.7 m/s <sup>2</sup>	EN62841-2-6
	7.7 m/s <sup>2</sup>	1.5 m/s <sup>2</sup>	Recommended practical operation*

\* The test condition of recommended practical operation meets EN 62841-2-6, except for the following points:

- Feed force is applied to the switch handle (main handle) for working accuracy and efficiency.
- The side grip/handle (auxiliary handle) is held to keep balance of the tool.

**NOTE:** The declared vibration total value(s) has been measured in accordance with a standard test method and may be used for comparing one tool with another.

**NOTE:** The declared vibration total value(s) may also be used in a preliminary assessment of exposure.

**⚠ WARNING:** The vibration emission during actual use of the power tool can differ from the declared value(s) depending on the ways in which the tool is used especially what kind of workpiece is processed.

**⚠ WARNING:** Be sure to identify safety measures to protect the operator that are based on an estimation of exposure in the actual conditions of use (taking account of all parts of the operating cycle such as the times when the tool is switched off and when it is running idle in addition to the trigger time).

## Declarations of Conformity

### For European countries only

The Declarations of conformity are included in Annex A to this instruction manual.

## SAFETY WARNINGS

### General power tool safety warnings

**⚠ WARNING** Read all safety warnings, instructions, illustrations and specifications provided with this power tool. Failure to follow all instructions listed below may result in electric shock, fire and/or serious injury.

### Save all warnings and instructions for future reference.

The term "power tool" in the warnings refers to your mains-operated (corded) power tool or battery-operated (cordless) power tool.

#### Work area safety

1. **Keep work area clean and well lit.** Cluttered or dark areas invite accidents.
2. **Do not operate power tools in explosive atmospheres, such as in the presence of flammable liquids, gases or dust.** Power tools create sparks which may ignite the dust or fumes.
3. **Keep children and bystanders away while operating a power tool.** Distractions can cause you to lose control.

#### Electrical safety

1. **Power tool plugs must match the outlet. Never modify the plug in any way. Do not use any adapter plugs with earthed (grounded) power tools.** Unmodified plugs and matching outlets will reduce risk of electric shock.
2. **Avoid body contact with earthed or grounded surfaces, such as pipes, radiators, ranges and refrigerators.** There is an increased risk of electric shock if your body is earthed or grounded.

3. **Do not expose power tools to rain or wet conditions.** Water entering a power tool will increase the risk of electric shock.
4. **Do not abuse the cord. Never use the cord for carrying, pulling or unplugging the power tool. Keep cord away from heat, oil, sharp edges or moving parts.** Damaged or entangled cords increase the risk of electric shock.
5. **When operating a power tool outdoors, use an extension cord suitable for outdoor use.** Use of a cord suitable for outdoor use reduces the risk of electric shock.
6. **If operating a power tool in a damp location is unavoidable, use a residual current device (RCD) protected supply.** Use of an RCD reduces the risk of electric shock.
7. **Power tools can produce electromagnetic fields (EMF) that are not harmful to the user.** However, users of pacemakers and other similar medical devices should contact the maker of their device and/or doctor for advice before operating this power tool.
9. **Always wear protective goggles to protect your eyes from injury when using power tools. The goggles must comply with ANSI Z87.1 in the USA, EN 166 in Europe, or AS/NZS 1336 in Australia/New Zealand. In Australia/New Zealand, it is legally required to wear a face shield to protect your face, too.**

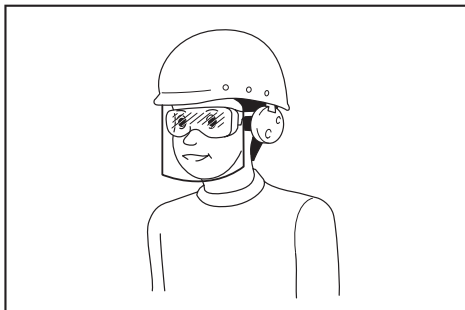

**It is an employer's responsibility to enforce the use of appropriate safety protective equipments by the tool operators and by other persons in the immediate working area.**

#### **Personal safety**

1. **Stay alert, watch what you are doing and use common sense when operating a power tool. Do not use a power tool while you are tired or under the influence of drugs, alcohol or medication.** A moment of inattention while operating power tools may result in serious personal injury.
2. **Use personal protective equipment. Always wear eye protection.** Protective equipment such as a dust mask, non-skid safety shoes, hard hat or hearing protection used for appropriate conditions will reduce personal injuries.
3. **Prevent unintentional starting. Ensure the switch is in the off-position before connecting to power source and/or battery pack, picking up or carrying the tool.** Carrying power tools with your finger on the switch or energising power tools that have the switch on invites accidents.
4. **Remove any adjusting key or wrench before turning the power tool on.** A wrench or a key left attached to a rotating part of the power tool may result in personal injury.
5. **Do not overreach. Keep proper footing and balance at all times.** This enables better control of the power tool in unexpected situations.
6. **Dress properly. Do not wear loose clothing or jewellery. Keep your hair and clothing away from moving parts.** Loose clothes, jewellery or long hair can be caught in moving parts.
7. **If devices are provided for the connection of dust extraction and collection facilities, ensure these are connected and properly used.** Use of dust collection can reduce dust-related hazards.
8. **Do not let familiarity gained from frequent use of tools allow you to become complacent and ignore tool safety principles.** A careless action can cause severe injury within a fraction of a second.

#### **Power tool use and care**

1. **Do not force the power tool. Use the correct power tool for your application.** The correct power tool will do the job better and safer at the rate for which it was designed.
2. **Do not use the power tool if the switch does not turn it on and off.** Any power tool that cannot be controlled with the switch is dangerous and must be repaired.
3. **Disconnect the plug from the power source and/or remove the battery pack, if detachable, from the power tool before making any adjustments, changing accessories, or storing power tools.** Such preventive safety measures reduce the risk of starting the power tool accidentally.
4. **Store idle power tools out of the reach of children and do not allow persons unfamiliar with the power tool or these instructions to operate the power tool.** Power tools are dangerous in the hands of untrained users.
5. **Maintain power tools and accessories. Check for misalignment or binding of moving parts, breakage of parts and any other condition that may affect the power tool's operation.** If damaged, have the power tool repaired before use. Many accidents are caused by poorly maintained power tools.
6. **Keep cutting tools sharp and clean.** Properly maintained cutting tools with sharp cutting edges are less likely to bind and are easier to control.
7. **Use the power tool, accessories and tool bits etc. in accordance with these instructions, taking into account the working conditions and the work to be performed.** Use of the power tool for operations different from those intended could result in a hazardous situation.
8. **Keep handles and grasping surfaces dry, clean and free from oil and grease.** Slippery handles and grasping surfaces do not allow for safe handling and control of the tool in unexpected situations.

9. **When using the tool, do not wear cloth work gloves which may be entangled.** The entanglement of cloth work gloves in the moving parts may result in personal injury.

#### Battery tool use and care

1. **Recharge only with the charger specified by the manufacturer.** A charger that is suitable for one type of battery pack may create a risk of fire when used with another battery pack.
2. **Use power tools only with specifically designed battery packs.** Use of any other battery packs may create a risk of injury and fire.
3. **When battery pack is not in use, keep it away from other metal objects, like paper clips, coins, keys, nails, screws or other small metal objects, that can make a connection from one terminal to another.** Shorting the battery terminals together may cause burns or a fire.
4. **Under abusive conditions, liquid may be ejected from the battery; avoid contact. If contact accidentally occurs, flush with water. If liquid contacts eyes, additionally seek medical help.** Liquid ejected from the battery may cause irritation or burns.
5. **Do not use a battery pack or tool that is damaged or modified.** Damaged or modified batteries may exhibit unpredictable behaviour resulting in fire, explosion or risk of injury.
6. **Do not expose a battery pack or tool to fire or excessive temperature.** Exposure to fire or temperature above 130 °C may cause explosion.
7. **Follow all charging instructions and do not charge the battery pack or tool outside the temperature range specified in the instructions.** Charging improperly or at temperatures outside the specified range may damage the battery and increase the risk of fire.

#### Service

1. **Have your power tool serviced by a qualified repair person using only identical replacement parts.** This will ensure that the safety of the power tool is maintained.
2. **Never service damaged battery packs.** Service of battery packs should only be performed by the manufacturer or authorized service providers.
3. **Follow instruction for lubricating and changing accessories.**

## CORDLESS ROTARY HAMMER SAFETY WARNINGS

#### Safety instructions for all operations

1. **Wear ear protectors.** Exposure to noise can cause hearing loss.
2. **Use auxiliary handle(s), if supplied with the tool.** Loss of control can cause personal injury.
3. **Hold the power tool by insulated gripping surfaces, when performing an operation where the cutting accessory may contact hidden wiring.** Cutting accessory contacting a "live" wire may make exposed metal parts of the power tool "live" and could give the operator an electric shock.

#### Safety instructions when using long drill bits with rotary hammers

1. **Always start drilling at low speed and with the bit tip in contact with the workpiece.** At higher speeds, the bit is likely to bend if allowed to rotate freely without contacting the workpiece, resulting in personal injury.
2. **Apply pressure only in direct line with the bit and do not apply excessive pressure.** Bits can bend, causing breakage or loss of control, resulting in personal injury.

#### Additional safety warnings

1. **Wear a hard hat (safety helmet), safety glasses and/or face shield.** Ordinary eye or sun glasses are NOT safety glasses. It is also highly recommended that you wear a dust mask and thickly padded gloves.
2. **Be sure the bit is secured in place before operation.**
3. **Under normal operation, the tool is designed to produce vibration.** The screws can come loose easily, causing a breakdown or accident. **Check tightness of screws carefully before operation.**
4. **In cold weather or when the tool has not been used for a long time, let the tool warm up for a while by operating it under no load. This will loosen up the lubrication.** Without proper warm-up, hammering operation is difficult.
5. **Always be sure you have a firm footing. Be sure no one is below when using the tool in high locations.**
6. **Hold the tool firmly with both hands.**
7. **Keep hands away from moving parts.**
8. **Do not leave the tool running. Operate the tool only when hand-held.**
9. **Do not point the tool at any one in the area when operating. The bit could fly out and injure someone seriously.**
10. **Do not touch the bit, parts close to the bit, or workpiece immediately after operation; they may be extremely hot and could burn your skin.**
11. **Some material contains chemicals which may be toxic. Take caution to prevent dust inhalation and skin contact. Follow material supplier safety data.**
12. **Always be sure that the tool is switched off and the battery cartridge and the bit are removed before handing the tool to other person.**
13. **Before operation, make sure that there is no buried object such as electric pipe, water pipe or gas pipe in the working area.** Otherwise, the drill bit/chisel may touch them, resulting an electric shock, electrical leakage or gas leak.
14. **Do not operate the tool at no-load unnecessarily.**

## SAVE THESE INSTRUCTIONS.

**⚠WARNING:** DO NOT let comfort or familiarity with product (gained from repeated use) replace strict adherence to safety rules for the subject product. MISUSE or failure to follow the safety rules stated in this instruction manual may cause serious personal injury.

## Important safety instructions for battery cartridge

1. Before using battery cartridge, read all instructions and cautionary markings on (1) battery charger, (2) battery, and (3) product using battery.
2. Do not disassemble or tamper with the battery cartridge. It may result in a fire, excessive heat, or explosion.
3. If operating time has become excessively shorter, stop operating immediately. It may result in a risk of overheating, possible burns and even an explosion.
4. If electrolyte gets into your eyes, rinse them out with clear water and seek medical attention right away. It may result in loss of your eyesight.
5. Do not short the battery cartridge:
  - (1) Do not touch the terminals with any conductive material.
  - (2) Avoid storing battery cartridge in a container with other metal objects such as nails, coins, etc.
  - (3) Do not expose battery cartridge to water or rain.

A battery short can cause a large current flow, overheating, possible burns and even a breakdown.

6. Do not store and use the tool and battery cartridge in locations where the temperature may reach or exceed 50 °C (122 °F).
7. Do not incinerate the battery cartridge even if it is severely damaged or is completely worn out. The battery cartridge can explode in a fire.
8. Do not nail, cut, crush, throw, drop the battery cartridge, or hit against a hard object to the battery cartridge. Such conduct may result in a fire, excessive heat, or explosion.
9. Do not use a damaged battery.
10. The contained lithium-ion batteries are subject to the Dangerous Goods Legislation requirements.

For commercial transports e.g. by third parties, forwarding agents, special requirement on packaging and labeling must be observed.  
For preparation of the item being shipped, consulting an expert for hazardous material is required. Please also observe possibly more detailed national regulations.  
Tape or mask off open contacts and pack up the battery in such a manner that it cannot move around in the packaging.
11. When disposing the battery cartridge, remove it from the tool and dispose of it in a safe place. Follow your local regulations relating to disposal of battery.
12. Use the batteries only with the products specified by Makita. Installing the batteries to non-compliant products may result in a fire, excessive heat, explosion, or leak of electrolyte.

13. If the tool is not used for a long period of time, the battery must be removed from the tool.
14. During and after use, the battery cartridge may take on heat which can cause burns or low temperature burns. Pay attention to the handling of hot battery cartridges.
15. Do not touch the terminal of the tool immediately after use as it may get hot enough to cause burns.
16. Do not allow chips, dust, or soil stuck into the terminals, holes, and grooves of the battery cartridge. It may cause heating, catching fire, burst and malfunction of the tool or battery cartridge, resulting in burns or personal injury.
17. Unless the tool supports the use near high-voltage electrical power lines, do not use the battery cartridge near high-voltage electrical power lines. It may result in a malfunction or breakdown of the tool or battery cartridge.
18. Keep the battery away from children.

## SAVE THESE INSTRUCTIONS.

**⚠ CAUTION:** Only use genuine Makita batteries. Use of non-genuine Makita batteries, or batteries that have been altered, may result in the battery bursting causing fires, personal injury and damage. It will also void the Makita warranty for the Makita tool and charger.

## Tips for maintaining maximum battery life

1. Charge the battery cartridge before completely discharged. Always stop tool operation and charge the battery cartridge when you notice less tool power.
2. Never recharge a fully charged battery cartridge. Overcharging shortens the battery service life.
3. Charge the battery cartridge with room temperature at 10 °C - 40 °C (50 °F - 104 °F). Let a hot battery cartridge cool down before charging it.
4. When not using the battery cartridge, remove it from the tool or the charger.
5. Charge the battery cartridge if you do not use it for a long period (more than six months).

## FUNCTIONAL DESCRIPTION

**CAUTION:** Always be sure that the tool is switched off and the battery cartridge is removed before adjusting or checking function on the tool.

### Installing or removing battery cartridge

**CAUTION:** Always switch off the tool before installing or removing of the battery cartridge.

**CAUTION:** Hold the tool and the battery cartridge firmly when installing or removing battery cartridge. Failure to hold the tool and the battery cartridge firmly may cause them to slip off your hands and result in damage to the tool and battery cartridge and a personal injury.

To install the battery cartridge, align the tongue on the battery cartridge with the groove in the housing and slip it into place. Insert it all the way until it locks in place with a little click. If you can see the red indicator as shown in the figure, it is not locked completely.

To remove the battery cartridge, slide it from the tool while sliding the button on the front of the cartridge.

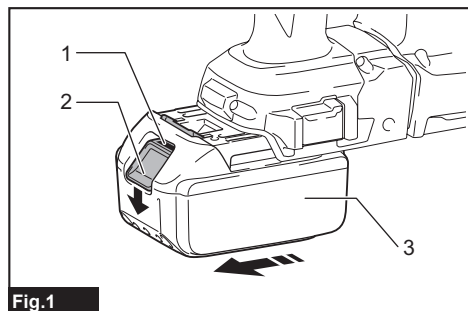

Fig.1

► 1. Red indicator 2. Button 3. Battery cartridge

**CAUTION:** Always install the battery cartridge fully until the red indicator cannot be seen. If not, it may accidentally fall out of the tool, causing injury to you or someone around you.

**CAUTION:** Do not install the battery cartridge forcibly. If the cartridge does not slide in easily, it is not being inserted correctly.

## Indicating the remaining battery capacity

*Only for battery cartridges with the indicator*

Press the check button on the battery cartridge to indicate the remaining battery capacity. The indicator lamps light up for a few seconds.

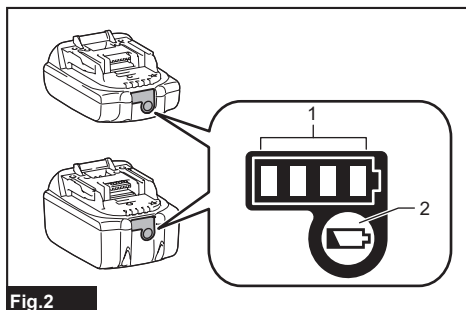

Fig.2

► 1. Indicator lamps 2. Check button

Indicator lamps			Remaining capacity
Lighted	Off	Blinking	
■ ■ ■ ■			75% to 100%
■ ■ ■ □			50% to 75%
■ ■ □ □			25% to 50%
■ □ □ □			0% to 25%
▣ □ □ □			Charge the battery.
■ ■ □ □			The battery may have malfunctioned.
□ □ ■ ■			

**NOTE:** Depending on the conditions of use and the ambient temperature, the indication may differ slightly from the actual capacity.

**NOTE:** The first (far left) indicator lamp will blink when the battery protection system works.

## Tool / battery protection system

The tool is equipped with a tool/battery protection system. This system automatically cuts off power to the motor to extend tool and battery life. The tool will automatically stop during operation if the tool or battery is placed under one of the following conditions:

### Overload protection

When the battery is operated in a manner that causes it to draw an abnormally high current, the tool automatically stops without any indication. In this situation, turn the tool off and stop the application that caused the tool to become overloaded. Then turn the tool on to restart.



## Overheat protection

When the tool or battery is overheated, the tool stops automatically. In this case, let the tool and battery cool before turning the tool on again.

**NOTE:** When the tool is overheated, the lamp blinks.

## Overdischarge protection

When the battery capacity is not enough, the tool stops automatically. In this case, remove the battery from the tool and charge the battery.

## Protections against other causes

Protection system is also designed for other causes that could damage the tool and allows the tool to stop automatically. Take all the following steps to clear the causes, when the tool has been brought to a temporary halt or stop in operation.

1. Turn the tool off, and then turn it on again to restart.
2. Charge the battery(ies) or replace it/them with recharged battery(ies).
3. Let the tool and battery(ies) cool down.

If no improvement can be found by restoring protection system, then contact your local Makita Service Center.

## Switch action

**⚠WARNING:** Before installing the battery cartridge into the tool, always check to see that the switch trigger actuates properly and returns to the "OFF" position when released.

To start the tool, simply pull the switch trigger. Tool speed is increased by increasing pressure on the switch trigger. Release the switch trigger to stop.

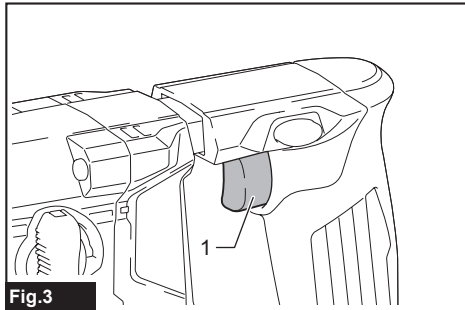

Fig.3

► 1. Switch trigger

## Lighting up the front lamp

**⚠CAUTION:** Do not look in the light or see the source of light directly.

Pull the switch trigger to light up the lamp. The lamp keeps on lighting while the switch trigger is being pulled. The lamp goes out approximately 10 seconds after releasing the switch trigger.

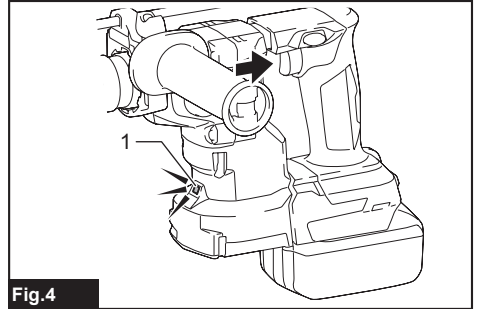

Fig.4

► 1. Lamp

**NOTE:** Use a dry cloth to wipe the dirt off the lens of the lamp. Be careful not to scratch the lens of lamp, or it may lower the illumination.

**NOTE:** When the tool is overheated, the lamp flashes. In this case, release the switch trigger and then cool down the tool/battery before operating again.

**NOTE:** The front lamp cannot be used while the dust collection system (optional accessory) is installed in the tool.

## Reversing switch action

**⚠CAUTION:** Always check the direction of rotation before operation.

**⚠CAUTION:** Use the reversing switch only after the tool comes to a complete stop. Changing the direction of rotation before the tool stops may damage the tool.

**⚠CAUTION:** When not operating the tool, always set the reversing switch lever to the neutral position.



This tool has a reversing switch to change the direction of rotation. Depress the reversing switch lever from the A side for clockwise rotation or from the B side for counterclockwise rotation.

When the reversing switch lever is in the neutral position, the switch trigger cannot be pulled.

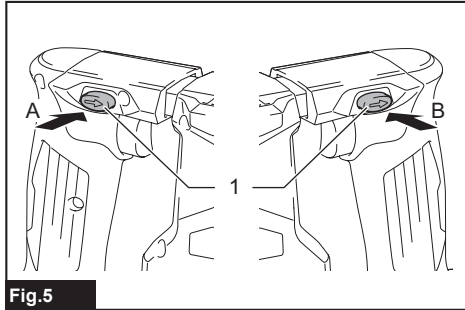

Fig.5

► 1. Reversing switch lever

## Selecting the action mode

**NOTICE:** Do not rotate the action mode changing knob when the tool is running. The tool will be damaged.

**NOTICE:** To avoid rapid wear on the mode change mechanism, be sure that the action mode changing knob is always positively located in one of the action mode positions.

## Rotation with hammering

For drilling in concrete, masonry, etc., rotate the action mode changing knob to the  symbol. Use a carbide-tipped drill bit.

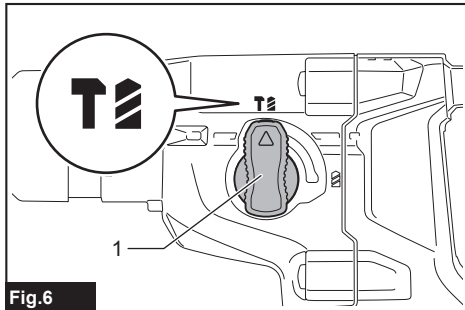



Fig.6

► 1. Action mode changing knob

## Rotation only

For drilling in wood, metal or plastic materials, rotate the action mode changing knob to the  symbol. Use a twist drill bit or wood drill bit.

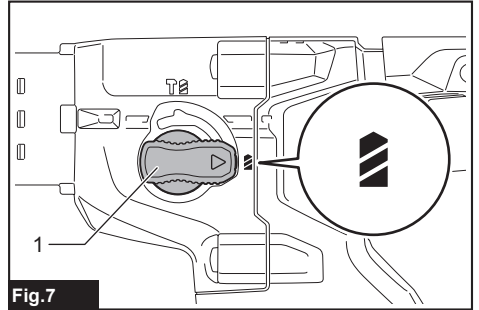

Fig.7

► 1. Action mode changing knob

## Electronic function

The tool is equipped with the electronic functions for easy operation.

- Electric brake  
This tool is equipped with an electric brake. If the tool consistently fails to quickly cease to function after the switch trigger is released, have the tool serviced at a Makita service center.
- Constant speed control  
The speed control function provides the constant rotation speed regardless of load conditions.

## ASSEMBLY

**CAUTION:** Always be sure that the tool is switched off and the battery cartridge is removed before carrying out any work on the tool.

## Side grip (auxiliary handle)

**CAUTION:** Always use the side grip to ensure safe operation.

**CAUTION:** After installing or adjusting the side grip, make sure that the side grip is firmly secured with the protrusions on the tool are fully engaged by the grooves on the side grip.

To install the side grip, follow the steps below.

1. Loosen the thumb screw on the side grip.

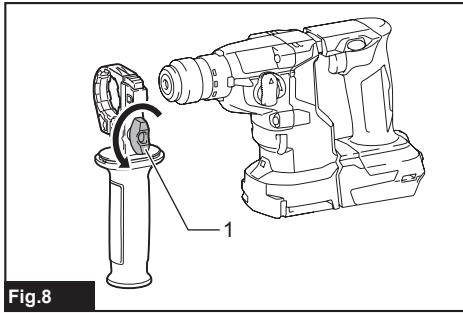

Fig.8

- ▶ 1. Thumb screw

2. Install the side grip so that the grooves on the grip fit in the protrusions on the tool while pressing the thumb screw.

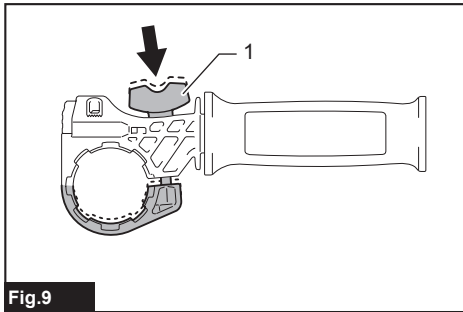

Fig.9

- ▶ 1. Thumb screw

3. Tighten the thumb screw to secure the grip. The grip can be fixed at desired angle.

## Installing or removing drill bit

### Grease

Clean the shank end of the bit and apply grease before installing the bit.

Coat the shank end of the bit beforehand with a small amount of grease (about 0.5 - 1 g). This chuck lubrication assures smooth action and longer service life.

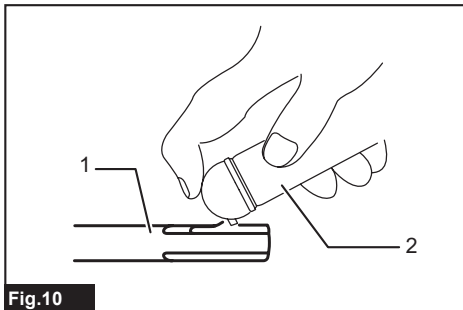

Fig.10

- ▶ 1. Shank end 2. Grease

Insert the drill bit into the tool. Turn the drill bit and push it in until it engages.

After installing the drill bit, always make sure that the drill bit is securely held in place by trying to pull it out.

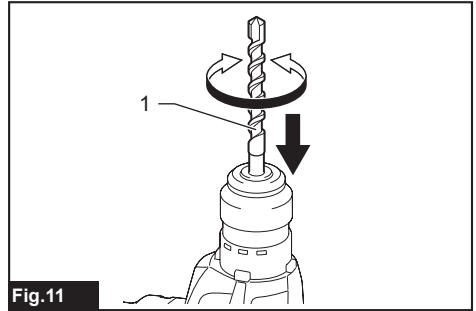

Fig.11

- ▶ 1. Drill bit

To remove the drill bit, push the chuck cover down all the way and pull the drill bit out.

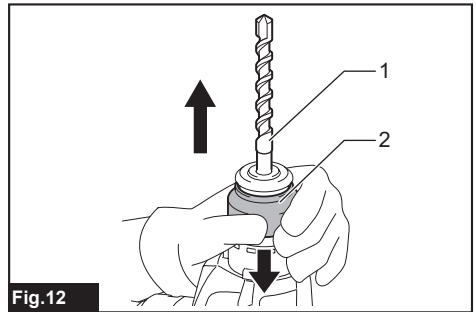

Fig.12

- ▶ 1. Drill bit 2. Chuck cover

## Depth gauge

The depth gauge is convenient for drilling holes of uniform depth. Press and hold the lock button, and then insert the depth gauge into the hole. Make sure that the toothed side of the depth gauge faces the marking.

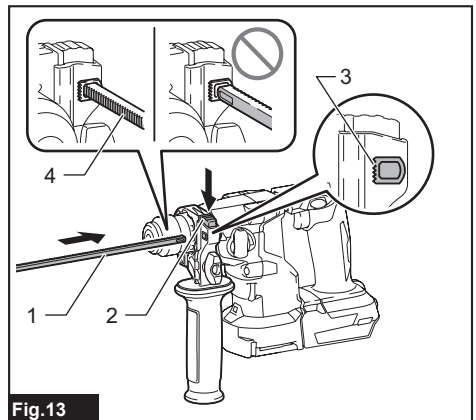

Fig.13

- ▶ 1. Depth gauge 2. Lock button 3. Marking 4. Toothed side

Adjust the depth gauge by moving it back and forth while pressing the lock button. After the adjustment, release the lock button to lock the depth gauge.

**NOTE:** Make sure that the depth gauge does not touch the main body of the tool when attaching it.

## Dust cup

### Optional accessory

Use the dust cup to prevent dust from falling over the tool and on yourself when performing overhead drilling operations. Attach the dust cup to the bit as shown in the figure. The size of bits which the dust cup can be attached to is as follows.

Model	Bit diameter
Dust cup 5	6 mm - 14.5 mm
Dust cup 9	12 mm - 16 mm

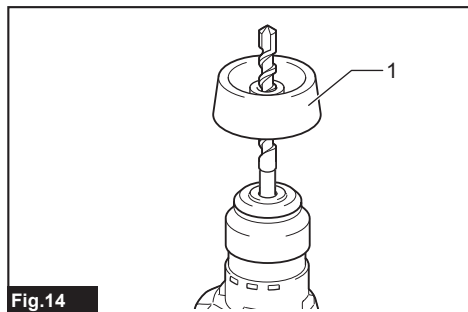

Fig.14

► 1. Dust cup

## Dust cup set

### Optional accessory

### Installing the dust cup set

**NOTICE:** Do not use the dust cup set when drilling in metal or similar. It may damage the dust cup set due to the heat produced by small metal dust or similar. Do not install or remove the dust cup set with the drill bit installed in the tool. It may damage the dust cup set and cause dust leak.

Before installing the dust cup set, remove the drill bit from the tool if installed.

1. Loosen the thumb screw on the side grip.

2. Install the dust cup set so that the claws of the dust cup fit in the slits on the side grip.

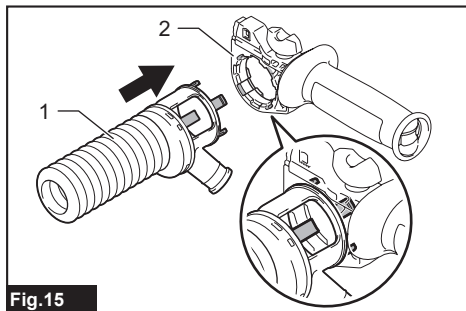

Fig.15

► 1. Dust cup set 2. Side grip

3. Install the side grip so that the groove on the grip fit in the protrusion on the tool. Tighten the thumb screw to secure the side grip.

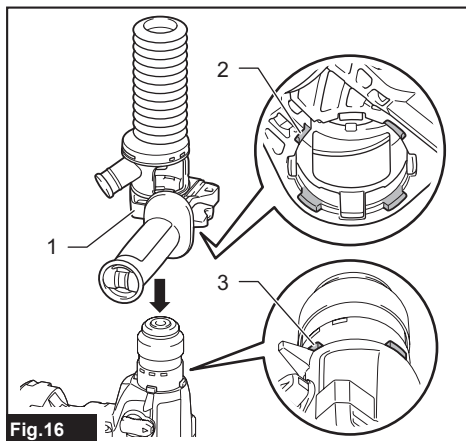

Fig.16

► 1. Side grip 2. Groove 3. Protrusion

**NOTE:** If you connect a vacuum cleaner to the dust cup set, remove the dust cap before connecting it.

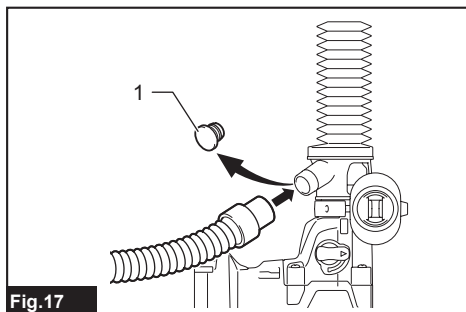

Fig.17

► 1. Dust cap

## Removing the drill bit

To remove the drill bit, pull the chuck cover down all the way and pull the drill bit out.

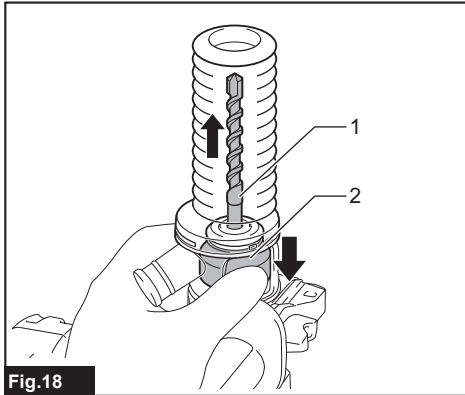

Fig.18

- 1. Drill bit 2. Chuck cover

## Removing the dust cup set

To remove the dust cup set, follow the steps below.

1. Loosen the thumb screw on the side grip. Remove the side grip from the tool.

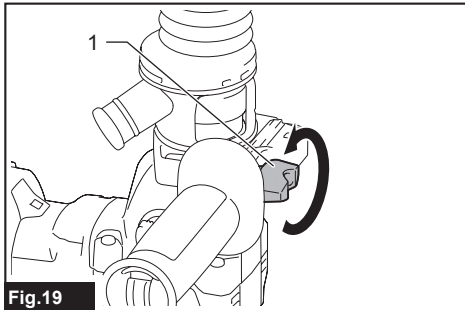

Fig.19

- 1. Thumb screw

2. Hold the root of dust cup and pull it out.

**NOTE:** If it is difficult to remove the dust cup set, remove the claws of the dust cup one by one by swinging and pulling the root of the dust cup.

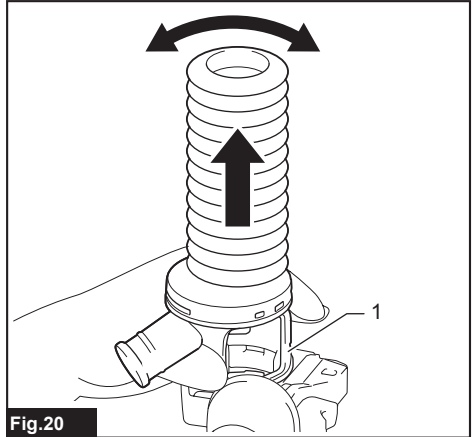

Fig.20

- 1. Dust cup

**NOTE:** If the cap comes off from the dust cup set, place it back to the original position.

To place the cap back to the original position, follow the steps below.

1. Turn the bellows counterclockwise and remove it from the dust cup set attachment unit while the bellows is unlocked.

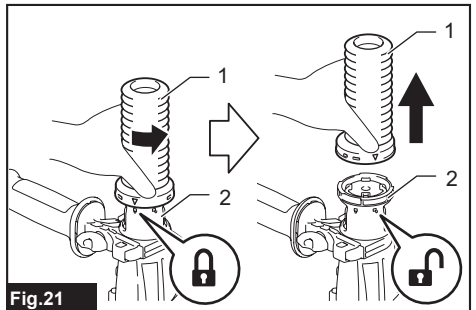

Fig.21

- 1. Bellows 2. Attachment unit

2. Set the cap back in place with its lettered side facing upwards.

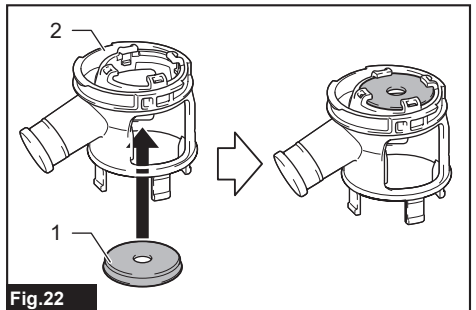

Fig.22

- 1. Cap 2. Attachment unit

3. Be sure that the grooves around the cap well fit in the lips of the upper opening of the attachment unit.

## Tool hanger

### Optional accessory

**⚠CAUTION:** Do not use damaged tool hanger and screw. Before use, always check for damages, cracks or deformations, and make sure that the screw is tightened.

**⚠CAUTION:** Install or remove the tool hanger on a stable table or surface. Be sure to use the screw provided with the tool hanger only. After installing the tool hanger, make sure that the tool hanger is securely installed with the screw.

**⚠CAUTION:** Do not remove the battery cartridge while hanging the tool. The tool may fall if the screw is not tightened.

The tool hanger is intended for connecting the lanyard (tether strap).

Before installing the tool hanger, remove the rubber cap from the screw hole in the mounting bracket. Insert the square nut under the bracket. Tighten the tool hanger with screw in place.

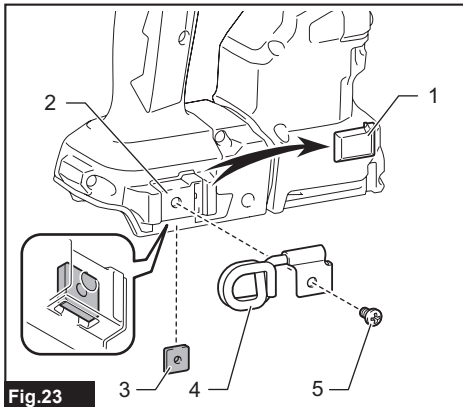

Fig.23

- 1. Rubber cap 2. Mounting bracket 3. Square nut  
4. Tool hanger 5. Screw

## Safety warnings about connecting lanyard (tether strap) to the tool hanger

**⚠Safety warnings specific for use at height**  
Read all safety warnings and instructions. Failure to follow the warnings and instructions may result in serious injury.

1. Always keep the tool tethered when working "at height". Maximum lanyard length is 2 m. The maximum permissible fall height for lanyard (tether strap) must not exceed 2 m.
2. Use only with lanyards appropriate for this tool type and rated for at least 6.0 kg.

3. Do not anchor the tool lanyard to anything on your body or on movable components. Anchor the tool lanyard to a rigid structure that can withstand the forces of a dropped tool.
4. Make sure the lanyard is properly secured at each end prior to use.
5. Inspect the tool and lanyard before each use for damage and proper function (including fabric and stitching). Do not use if damaged or not functioning properly.
6. Do not wrap lanyards around or allow them to come in contact with sharp or rough edges.
7. Fasten the other end of the lanyard outside the working area so that a falling tool is held securely.
8. Attach the lanyard so that the tool will move away from the operator if it falls. Dropped tools will swing on the lanyard, which could cause injury or loss of balance.
9. Do not use near moving parts or running machinery. Failure to do so may result in a crush or entanglement hazard.
10. Do not carry the tool by the attachment device or the lanyard.
11. Only transfer the tool between your hands while you are properly balanced.
12. Do not attach lanyards to the tool in a way that keeps switches or trigger-lock (if supplied) from operating properly.
13. Avoid getting tangled in the lanyard.
14. Keep lanyard away from the drilling area of the tool.
15. Use a locking carabiner (multi-action and screw gate type). Do not use single action spring clip carabiners.
16. In the event the tool is dropped, it must be tagged and removed from service, and should be inspected by a Makita Factory or Authorized Service Center.
17. Do not hang the tool on your waist. Heated tool and its accessory may touch your skin and burn injury result.

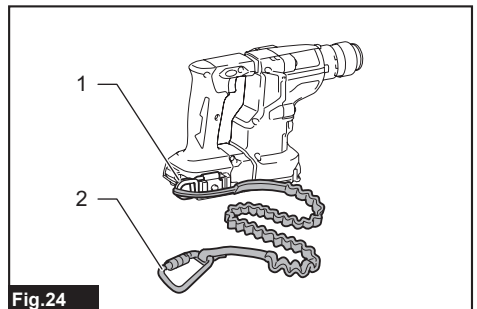

Fig.24

- 1. Tool hanger 2. Lanyard (tether strap)

# DUST COLLECTION SYSTEM

## Optional accessory

The dust collection system is designed to collect dusts effectively when the concrete drilling operation.

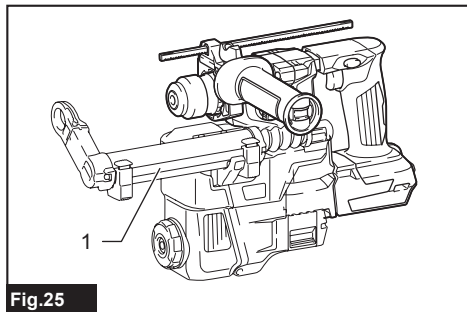

Fig.25

► 1. Dust collection system

**CAUTION:** The dust collection system is intended for drilling in concrete only. Do not use the dust collection system for drilling in metal or wood.

**CAUTION:** When using the tool with the dust collection system, be sure to attach the filter to the dust collection system to prevent dust inhalation.

**CAUTION:** Before using the dust collection system, check that the filter is not damaged and the inner pipe is free of dust and foreign matter. Failure to do so may cause dust inhalation.

**CAUTION:** The dust collection system collects the generated dust at a considerable rate, but not all dust can be collected.

**NOTICE:** Do not use the dust collection system for core drilling or chiseling.

**NOTICE:** Do not use the dust collection system for metal or wood. The dust collection system is intended for concrete only.

**NOTICE:** Do not use the dust collection system for drilling in wet concrete or use this system in wet environment. Failure to do so may cause malfunction.

## Installing or removing

**NOTICE:** Before installing the dust collection system, clean the joint parts of the tool and the dust collection system. Foreign matters on the joint parts may cause it difficult to install the dust collection system. If any dust remains on the air duct, the dust comes into the tool and causes jam in the airflow or breakage of the tool.

To install the dust collection system, insert the tool completely into the dust collection system until the tool is locked in place with a little click.

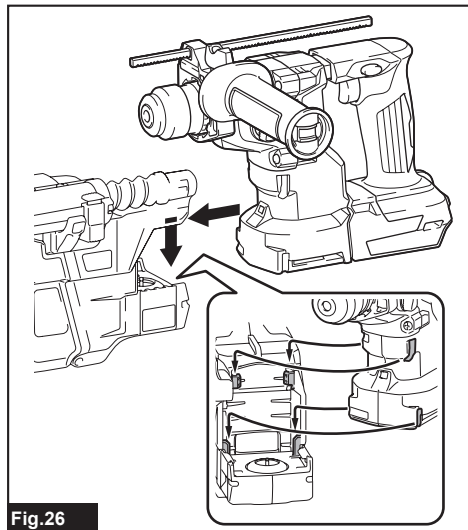

Fig.26

To remove the dust collection system, pull up the tool while pressing the lock-off button.

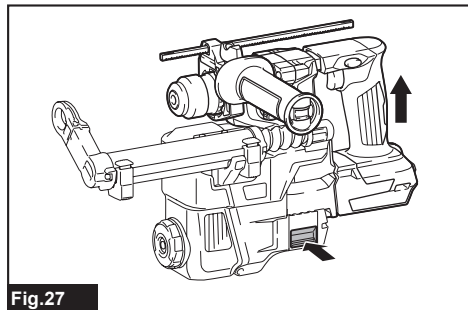

Fig.27

► 1. Lock-off button

## Adjusting nozzle position

**CAUTION:** Do not point the nozzle at yourself or others when releasing the nozzle by pushing the guide adjustment button.

Slide in and out the nozzle guide while pressing the guide adjustment button, and then release the button at an exact position where the tip of the drill bit sits just behind the front surface of the nozzle.

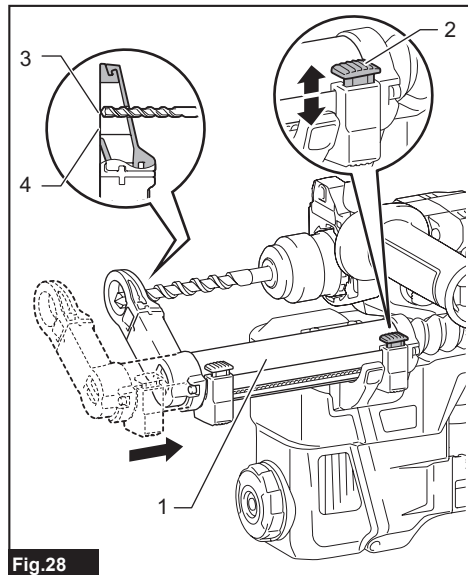

Fig.28

- 1. Nozzle guide 2. Guide adjustment button 3. Tip of drill bit 4. Front surface of nozzle

## Adjusting drilling depths

Drilling depths can be adjusted by changing the lengths between the depth adjustment button and the support arm for nozzle guide. Press and hold the depth adjustment button and slide it to your desired position.

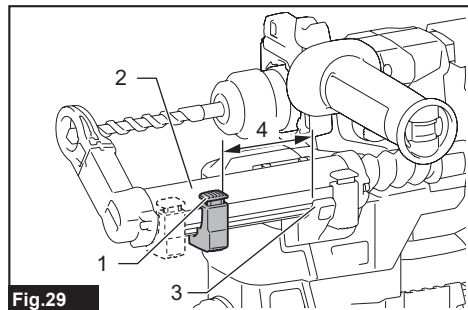

Fig.29

- 1. Support arm for nozzle guide 2. Depth adjustment button 3. Drilling depths 4. Drilling depths

## Beating dust on the filter

**CAUTION:** Do not turn the dial on the dust case while the dust case is removed from the dust collection system. Doing so may cause dust inhalation.

**CAUTION:** Always switch off the tool when turning the dial on the dust case. Turning the dial while the tool is running may result in the loss of control of the tool.

By beating the dust on the filter inside the dust case, you can keep the vacuum efficiency and also reduce the number of times to dispose of the dust. Turn the dial on the dust case three times after collecting every 50,000 mm<sup>3</sup> of dust or when you feel the vacuum performance declined.

**NOTE:** 50,000 mm<sup>3</sup> of dust equivalents to drilling 10 holes of  $\varnothing 10$  mm and 65 mm depth.

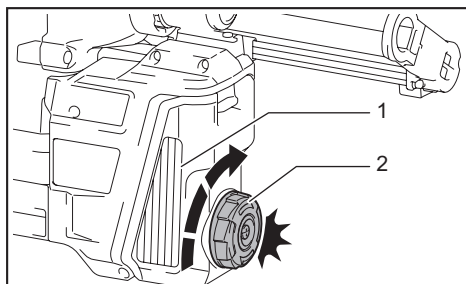

Fig.30

- 1. Dust case 2. Dial

## Disposing of dust

**CAUTION:** Always be sure that the tool is switched off and the battery cartridge is removed before carrying out any work on the tool.

**CAUTION:** Be sure to wear dust mask when disposing of dust.

**CAUTION:** Be sure that the tool is completely stopped when disposing of dust.

**CAUTION:** Empty the dust case regularly before the dust case becomes full. Failure to do so may decrease the dust collection performance and cause dust inhalation.

**CAUTION:** The performance of dust collection decreases if the filter in the dust case become clogged. Replace the filter with new one after approximately 200 times of dust fulfillment as a guide. Failure to do so may cause dust inhalation.



1. Remove the dust case while pressing down the lever of the dust case.

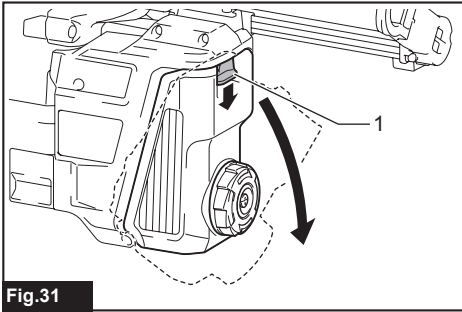

Fig.31

- ▶ 1. Lever

2. Open the cover of the dust case.

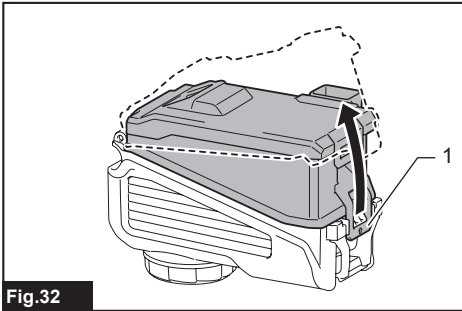

Fig.32

- ▶ 1. Cover

3. Dispose of the dust, and then clean the filter.

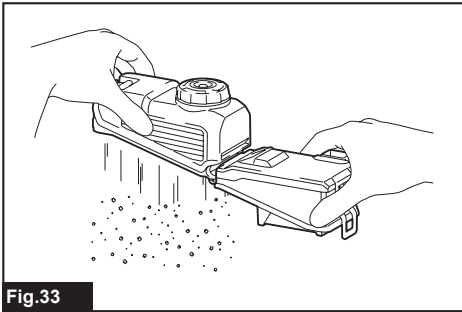

Fig.33

**NOTICE:** When cleaning the filter, tap the case of the filter gently by hand to remove dust. Do not tap the filter directly; touch the filter with brush or similar; or blow compressed air on the filter. Doing so may damage the filter.

## Replacing filter of dust case

1. Remove the dust case while pressing down the lever of the dust case.

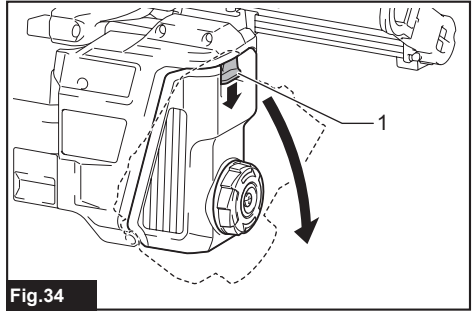

Fig.34

- ▶ 1. Lever

2. Open the filter cover of the dust case.

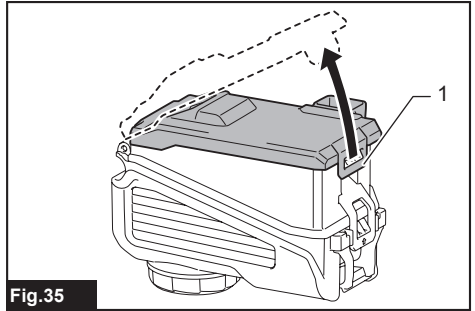

Fig.35

- ▶ 1. Filter cover

3. Remove the filter from the filter case.

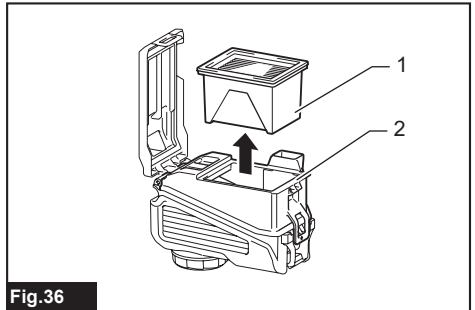

Fig.36

- ▶ 1. Filter 2. Filter case

4. Attach a new filter to the filter case, and then attach the filter cover.

5. Close the cover of the dust case, and then attach the dust case to the dust collection system.

## Replacing sealing cap

1. Insert a flat-blade screwdriver into one of the grooves placed on the sides of the nozzle head. Tilt the flat-blade screwdriver at an angle to squeeze and pop the cube hook of the sealing cap out. Then peel the rubber edge of the sealing cap away from the rim of the nozzle head opening.

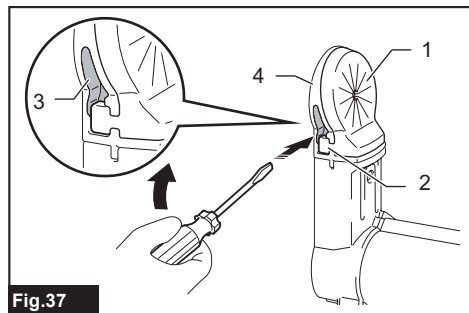

Fig.37

► 1. Sealing cap 2. Cube hook 3. Groove 4. Nozzle head

2. Set one of cube hooks of a new sealing cap into the lower part of the groove in the nozzle head with a recessed surface of the sealing cap facing forward.

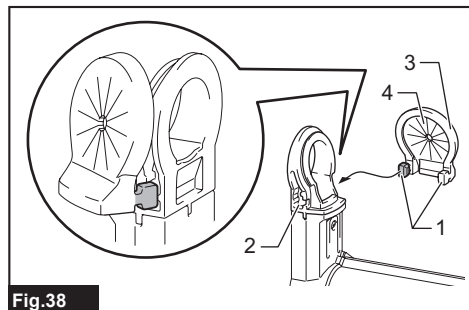

Fig.38

► 1. Cube hooks 2. Lower part of the groove 3. Sealing cap 4. Recessed surface

3. Place the other hook into the opposite side, while repositioning the sealing cap to fit finely to the nozzle head.

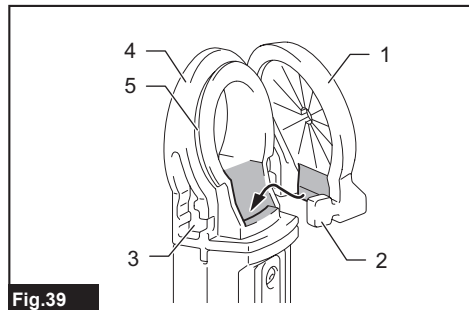

Fig.39

► 1. Sealing cap 2. Cube hook 3. Lower part of the groove 4. Nozzle head 5. Rims

4. Gently lay the rubber edge of the sealing cap down over the rim of the nozzle head opening from bottom to top.

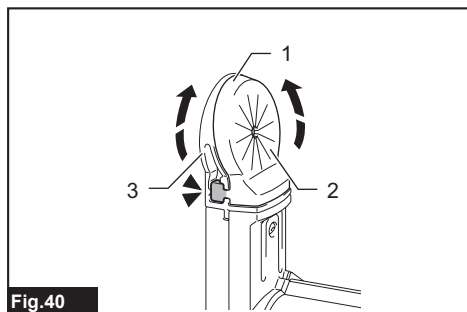

Fig.40

► 1. Rubber edge 2. Sealing cap 3. Nozzle head

## OPERATION

**CAUTION:** Always use the side grip (auxiliary handle) and firmly hold the tool by both side grip and switch handle during operations.

**CAUTION:** Always make sure that the work-piece is secured before operation.

**CAUTION:** Do not pull the tool out forcibly even the bit gets stuck. Loss of control may cause injury.

**NOTICE:** Before using the dust collection system with the tool, read the section about the dust collection system.

**NOTE:** If the battery cartridge is in low temperature, the tool's capability may not be fully obtained. In this case, warm up the battery cartridge by using the tool with no load for a while to fully obtain the tool's capability.

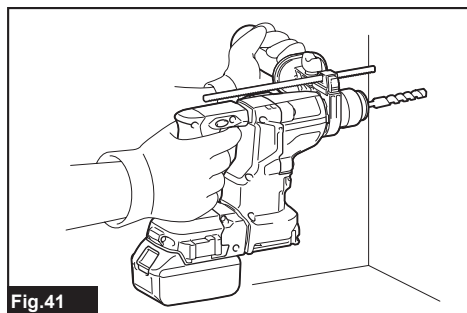



Fig.41

## Hammer drilling operation

**CAUTION:** There is tremendous and sudden twisting force exerted on the tool/drill bit at the time of hole break-through, when the hole becomes clogged with chips and particles, or when striking reinforcing rods embedded in the concrete. **Always use the side grip (auxiliary handle) and firmly hold the tool by both side grip and switch handle during operations.** Failure to do so may result in the loss of control of the tool and potentially severe injury.

Set the action mode changing knob to the  symbol. Position the drill bit at the desired location for the hole, then pull the switch trigger.

Apply feed force to the switch handle (main handle) for working accuracy and efficiency, and hold the side grip (auxiliary handle) to keep balance of the tool. Keep the tool in position and prevent it from slipping away from the hole.

Do not apply more pressure when the hole becomes clogged with chips or particles. Instead, run the tool at an idle, then remove the drill bit partially from the hole. By repeating this several times, the hole will be cleaned out and normal drilling may be resumed.

**NOTE:** Eccentricity in the drill bit rotation may occur while operating the tool with no load. The tool automatically centers itself during operation. This does not affect the drilling precision.

## Drilling in wood or metal

**CAUTION:** Hold the tool firmly and exert care when the drill bit begins to break through the workpiece. There is a tremendous force exerted on the tool/drill bit at the time of hole break through.

**CAUTION:** A stuck drill bit can be removed simply by setting the reversing switch to reverse rotation in order to back out. However, the tool may back out abruptly if you do not hold it firmly.

**CAUTION:** Always secure workpieces in a vise or similar hold-down device.

**NOTICE:** Never use “rotation with hammering” when the drill chuck is installed on the tool. The drill chuck may be damaged.

Also, the drill chuck will come off when reversing the tool.

**NOTICE:** Pressing excessively on the tool will not speed up the drilling. In fact, this excessive pressure will only serve to damage the tip of your drill bit, decrease the tool performance and shorten the service life of the tool.

Set the action mode changing knob to the  symbol. Attach the chuck adapter to a keyless drill chuck to which 1/2"-20 size screw can be installed, and then install them to the tool. When installing it, refer to the section “Installing or removing drill bit”.

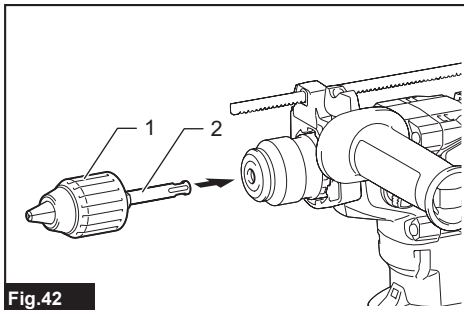

Fig.42

► 1. Drill chuck assembly 2. Chuck adapter

## Blow-out bulb

### Optional accessory

After drilling the hole, use the blow-out bulb to clean the dust out of the hole.

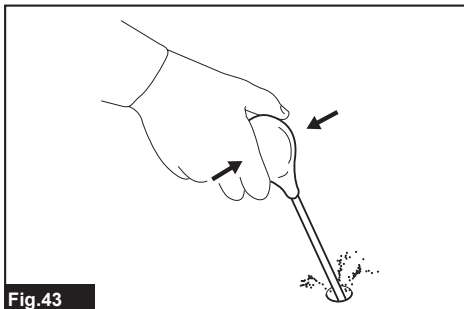

Fig.43

## Using dust cup set

### Optional accessory

Fit the dust cup set against the ceiling when operating the tool.

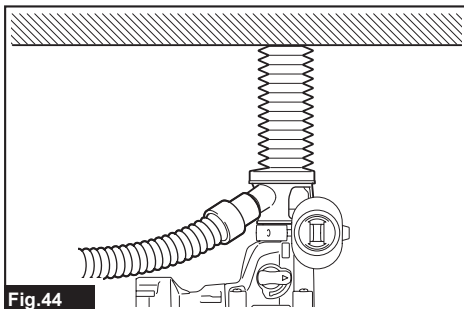

Fig.44

**NOTICE:** Do not use the dust cup set when drilling in metal or similar. It may damage the dust cup set due to the heat produced by small metal dust or similar.

**NOTICE:** Do not install or remove the dust cup set with the drill bit installed in the tool. It may damage the dust cup set and cause dust leak.

## MAINTENANCE

**⚠ CAUTION:** Always be sure that the tool is switched off and the battery cartridge is removed before attempting to perform inspection or maintenance.

**NOTICE:** Never use gasoline, benzine, thinner, alcohol or the like. Discoloration, deformation or cracks may result.

To maintain product SAFETY and RELIABILITY, repairs, any other maintenance or adjustment should be performed by Makita Authorized or Factory Service Centers, always using Makita replacement parts.

## OPTIONAL ACCESSORIES

**⚠ CAUTION:** These accessories or attachments are recommended for use with your Makita tool specified in this manual. The use of any other accessories or attachments might present a risk of injury to persons. Only use accessory or attachment for its stated purpose.

If you need any assistance for more details regarding these accessories, ask your local Makita Service Center.

- Carbide-tipped drill bits (SDS-Plus carbide-tipped bits)
- Chuck adapter
- Keyless drill chuck
- Bit grease
- Depth gauge
- Blow-out bulb
- Dust cup
- Dust cup set
- Dust collection system
- Tool hanger
- Makita genuine battery and charger

**NOTE:** Some items in the list may be included in the tool package as standard accessories. They may differ from country to country.

**Makita Europe N.V.** Jan-Baptist Vinkstraat 2,  
3070 Kortenberg, Belgium

**Makita Corporation** 3-11-8, Sumiyoshi-cho,  
Anjo, Aichi 446-8502 Japan

[www.makita.com](http://www.makita.com)

885A17-224 EN 20221116
------------------------------