

INSTRUCTION MANUAL

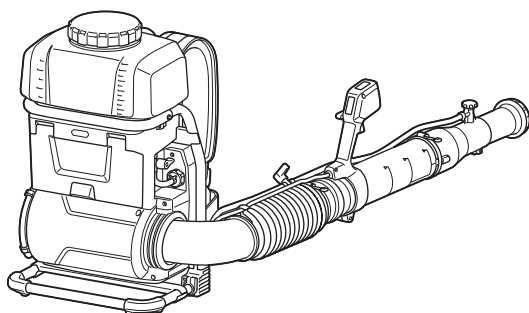

# Cordless Backpack Mist Blower PM001G



Read before use.

# SPECIFICATIONS

<b>Model:</b>		<b>PM001G</b>
Capacities	Air volume	7.4 - 14.3 m <sup>3</sup> /min *1
	Air speed (average)	28.0 - 53.0 m/s
	Air speed (max.)	34.0 - 64.0 m/s
Tank capacity		15 l
Volume of total residual		50 ml or less
Dimensions (L x W x H) (with end nozzle)		320 mm x 600 mm x 690 mm
Rated voltage		D.C. 36 V - 40 V max
Net weight	*2	11.9 kg
	*3	13.2 - 15.7 kg
Protection degree		IPX4

- Due to our continuing program of research and development, the specifications herein are subject to change without notice.
- Specifications may differ from country to country.

\*1: Maximum air flow rate is 858 m<sup>3</sup>/h.

\*2: Weight when the tank is empty, without the batteries, with pipes, nozzle and harnesses.

\*3: The lightest and heaviest combination of weight, according to EPTA-Procedure 01/2014. The weight may differ depending on the attachment(s), including the battery cartridge(s).

## Applicable battery cartridge and charger

Battery cartridge	BL4050F / BL4080F
Charger	DC40RA / DC40RB / DC40RC

- Some of the battery cartridges and chargers listed above may not be available depending on your region of residence.

**⚠ WARNING: Only use the battery cartridges and chargers listed above.** Use of any other battery cartridges and chargers may cause injury and/or fire.

**⚠ WARNING: Do not use a corded power supply such as portable power pack with this machine.**

## Spraying specifications

### Horizontal spray range

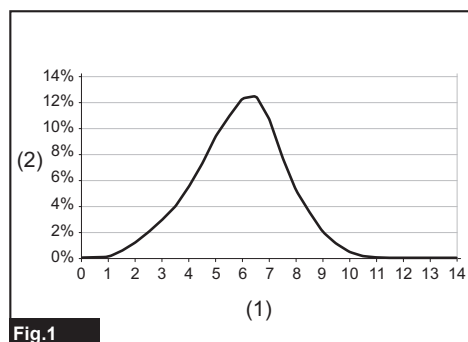

**Fig.1**

- 1. Distance from flow delivery (m) 2. Percentage of medium deposited on the ground

## Droplet size

### Droplet size with standard nozzle

Adjustment knob setting	Dv 0.1	Dv 0.5	Dv 0.9
1	22 µm	57 µm	112 µm
2	37 µm	102 µm	251 µm
3	40 µm	111 µm	267 µm
4	42 µm	115 µm	280 µm

### Droplet size with ULV nozzle

Adjustment knob setting	Dv 0.1	Dv 0.5	Dv 0.9
1 - 4	14 µm	41 µm	85 µm

## Discharge rate for working positions

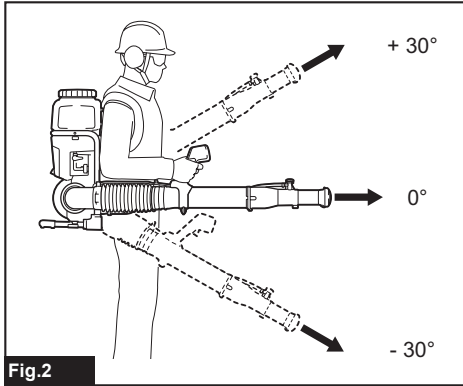

Fig.2

### Discharge rate with standard nozzle

Adjustment knob setting	Nozzle angle		
	-30°	0°	30°
1	0.23 l/min	0.19 l/min	0.12 l/min
2	1.13 l/min	0.71 l/min	0.34 l/min
3	1.37 l/min	0.95 l/min	0.49 l/min
4	1.55 l/min	1.21 l/min	0.51 l/min

### Discharge rate with ULV nozzle

Adjustment knob setting	Nozzle angle		
	-30°	0°	30°
1 - 4	0.05 l/min	0.04 l/min	0.03 l/min

**NOTE:** The values in this spraying specifications may differ depending on the working conditions or ambient temperature.

## Symbols

The followings show the symbols which may be used for the equipment. Be sure that you understand their meaning before use.

	Take particular care and attention.
	Read instruction manual.
	Wear eye and ear protection.
	Wear respiratory protection.
	Do not expose to moisture.
	Wear sturdy boots with nonslip soles. Steelted safety boots are recommended.
	Wear protective gloves.



Wear protective clothes.



Keep bystanders away when spraying.



Keep hands away from rotating parts.



Long hair may cause entanglement accident.



Keep bystanders away.



Weight when the tank is empty.



Weight when the tank is full.



Ni-MH  
Li-ion

Only for EU countries  
Due to the presence of hazardous components in the equipment, waste electrical and electronic equipment, accumulators and batteries may have a negative impact on the environment and human health. Do not dispose of electrical and electronic appliances or batteries with household waste!

In accordance with the European Directive on waste electrical and electronic equipment and on accumulators and batteries and waste accumulators and batteries, as well as their adaptation to national law, waste electrical equipment, batteries and accumulators should be stored separately and delivered to a separate collection point for municipal waste, operating in accordance with the regulations on environmental protection.

This is indicated by the symbol of the crossed-out wheeled bin placed on the equipment.



Guaranteed sound power level according to EU Outdoor Noise Directive.



Sound power level according to Australia NSW Noise Control Regulation.

## Intended use

The machine is intended for blowing mist.

# SAFETY WARNINGS

## General power tool safety warnings

**⚠ WARNING** Read all safety warnings, instructions, illustrations and specifications provided with this power tool. Failure to follow all instructions listed below may result in electric shock, fire and/or serious injury.

## Save all warnings and instructions for future reference.

The term "power tool" in the warnings refers to your mains-operated (corded) power tool or battery-operated (cordless) power tool.

### Work area safety

1. **Keep work area clean and well lit.** Cluttered or dark areas invite accidents.
2. **Do not operate power tools in explosive atmospheres, such as in the presence of flammable liquids, gases or dust.** Power tools create sparks which may ignite the dust or fumes.
3. **Keep children and bystanders away while operating a power tool.** Distractions can cause you to lose control.

### Electrical safety

1. **Power tool plugs must match the outlet. Never modify the plug in any way. Do not use any adapter plugs with earthed (grounded) power tools.** Unmodified plugs and matching outlets will reduce risk of electric shock.
2. **Avoid body contact with earthed or grounded surfaces, such as pipes, radiators, ranges and refrigerators.** There is an increased risk of electric shock if your body is earthed or grounded.
3. **Do not expose power tools to rain or wet conditions.** Water entering a power tool will increase the risk of electric shock.
4. **Do not abuse the cord. Never use the cord for carrying, pulling or unplugging the power tool. Keep cord away from heat, oil, sharp edges or moving parts.** Damaged or entangled cords increase the risk of electric shock.
5. **When operating a power tool outdoors, use an extension cord suitable for outdoor use.** Use of a cord suitable for outdoor use reduces the risk of electric shock.
6. **If operating a power tool in a damp location is unavoidable, use a residual current device (RCD) protected supply.** Use of an RCD reduces the risk of electric shock.
7. **Power tools can produce electromagnetic fields (EMF) that are not harmful to the user.** However, users of pacemakers and other similar medical devices should contact the maker of their device and/or doctor for advice before operating this power tool.

### Personal safety

1. **Stay alert, watch what you are doing and use common sense when operating a power tool. Do not use a power tool while you are tired or under the influence of drugs, alcohol or medication.** A moment of inattention while operating power tools may result in serious personal injury.
2. **Use personal protective equipment. Always wear eye protection.** Protective equipment such as a dust mask, non-skid safety shoes, hard hat or hearing protection used for appropriate conditions will reduce personal injuries.
3. **Prevent unintentional starting. Ensure the switch is in the off-position before connecting to power source and/or battery pack, picking up or carrying the tool.** Carrying power tools with your finger on the switch or energising power tools that have the switch on invites accidents.

4. **Remove any adjusting key or wrench before turning the power tool on.** A wrench or a key left attached to a rotating part of the power tool may result in personal injury.
5. **Do not overreach. Keep proper footing and balance at all times.** This enables better control of the power tool in unexpected situations.
6. **Dress properly. Do not wear loose clothing or jewellery. Keep your hair and clothing away from moving parts.** Loose clothes, jewellery or long hair can be caught in moving parts.
7. **If devices are provided for the connection of dust extraction and collection facilities, ensure these are connected and properly used.** Use of dust collection can reduce dust-related hazards.
8. **Do not let familiarity gained from frequent use of tools allow you to become complacent and ignore tool safety principles.** A careless action can cause severe injury within a fraction of a second.
9. **Always wear protective goggles to protect your eyes from injury when using power tools. The goggles must comply with ANSI Z87.1 in the USA, EN 166 in Europe, or AS/NZS 1336 in Australia/New Zealand. In Australia/New Zealand, it is legally required to wear a face shield to protect your face, too.**

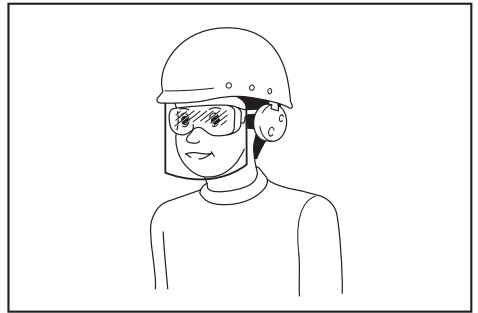

It is an employer's responsibility to enforce the use of appropriate safety protective equipments by the tool operators and by other persons in the immediate working area.

### Power tool use and care

1. **Do not force the power tool. Use the correct power tool for your application.** The correct power tool will do the job better and safer at the rate for which it was designed.
2. **Do not use the power tool if the switch does not turn it on and off.** Any power tool that cannot be controlled with the switch is dangerous and must be repaired.
3. **Disconnect the plug from the power source and/or remove the battery pack, if detachable, from the power tool before making any adjustments, changing accessories, or storing power tools.** Such preventive safety measures reduce the risk of starting the power tool accidentally.
4. **Store idle power tools out of the reach of children and do not allow persons unfamiliar with the power tool or these instructions to operate the power tool.** Power tools are dangerous in the hands of untrained users.

5. **Maintain power tools and accessories. Check for misalignment or binding of moving parts, breakage of parts and any other condition that may affect the power tool's operation. If damaged, have the power tool repaired before use.** Many accidents are caused by poorly maintained power tools.
6. **Keep cutting tools sharp and clean.** Properly maintained cutting tools with sharp cutting edges are less likely to bind and are easier to control.
7. **Use the power tool, accessories and tool bits etc. in accordance with these instructions, taking into account the working conditions and the work to be performed.** Use of the power tool for operations different from those intended could result in a hazardous situation.
8. **Keep handles and grasping surfaces dry, clean and free from oil and grease.** Slippery handles and grasping surfaces do not allow for safe handling and control of the tool in unexpected situations.
9. **When using the tool, do not wear cloth work gloves which may be entangled.** The entanglement of cloth work gloves in the moving parts may result in personal injury.

#### Battery tool use and care

1. **Recharge only with the charger specified by the manufacturer.** A charger that is suitable for one type of battery pack may create a risk of fire when used with another battery pack.
2. **Use power tools only with specifically designated battery packs.** Use of any other battery packs may create a risk of injury and fire.
3. **When battery pack is not in use, keep it away from other metal objects, like paper clips, coins, keys, nails, screws or other small metal objects, that can make a connection from one terminal to another.** Shorting the battery terminals together may cause burns or a fire.
4. **Under abusive conditions, liquid may be ejected from the battery; avoid contact. If contact accidentally occurs, flush with water. If liquid contacts eyes, additionally seek medical help.** Liquid ejected from the battery may cause irritation or burns.
5. **Do not use a battery pack or tool that is damaged or modified.** Damaged or modified batteries may exhibit unpredictable behaviour resulting in fire, explosion or risk of injury.
6. **Do not expose a battery pack or tool to fire or excessive temperature.** Exposure to fire or temperature above 130 °C may cause explosion.
7. **Follow all charging instructions and do not charge the battery pack or tool outside the temperature range specified in the instructions.** Charging improperly or at temperatures outside the specified range may damage the battery and increase the risk of fire.

#### Service

1. **Have your power tool serviced by a qualified repair person using only identical replacement parts.** This will ensure that the safety of the power tool is maintained.

2. **Never service damaged battery packs.** Service of battery packs should only be performed by the manufacturer or authorized service providers.
3. **Follow instruction for lubricating and changing accessories.**

## Cordless Backpack Mist Blower Safety Instructions

**⚠WARNING:** Read all safety warnings and all instructions. Failure to follow the warnings and instructions may result in electric shock, fire and/or serious injury.

## Save all warnings and instructions for future reference.

#### General Instructions

1. **To ensure correct and safe operation, the user must read, understand and follow this instruction manual to assure familiarity with the handling of the machine. Users insufficiently informed will risk danger to themselves as well as others due to improper handling.**
2. **It is recommended to lend the machine only to people who have proven to be experienced with mist blowers.**
3. **Children and young persons aged under 18 years must not be allowed to operate the machine. Persons over the age of 16 years may however use the machine for the purpose of being trained only while under the direct supervision of a qualified trainer.**
4. **Only use plant protection products that are specifically approved for use with mist blowers by the manufacturer and that meet all applicable safety regulations, standards, and ordinances.**
5. **All operating and servicing people should be trained and familiarized with the proper handling procedures for the chemical products being used, as well as with liquid chemical disposal regulations.**
6. **To reduce the risk of injury when using chemical products, wear proper protective apparel when filling, using and cleaning the mist blower. Always follow all of the chemical manufacturer's instructions with respect to proper eye, skin and respiratory protection.**
7. **When using toxic chemicals, the operator and any bystanders may need to wear a properly fitted respirator for the chemical being used. Refer to the chemical product label. Breathing toxic chemicals can cause serious or fatal injury.**

#### Intended use of the machine

1. **The machine is only intended for spraying liquid chemicals and other liquids to control pests and weeds in fruit, flower and vegetable gardens, on trees and bushes and on other plants, such as coffee, tobacco and cotton. It is also useful for the maintenance of young trees to control the bark beetle and other pests and plant diseases. Never use for any other purposes.**

## Training

1. Read the instructions carefully. Be familiar with the controls and the correct use of the machine.
2. Never allow children, persons with reduced physical, sensory or mental capabilities or lack of experience and knowledge or people unfamiliar with these instructions to use the machine. Local regulations may restrict the age of the operator.
3. Never operate the machine while people, especially children, or pets are nearby.
4. Keep in mind that the operator or user is responsible for accidents or hazards occurring to other people or their property.

## Preparation

1. Always wear substantial footwear and long trousers while operating the machine.
2. Do not wear loose clothing or jewellery that can be drawn into the air inlet. Keep long hair away from the air inlets.
3. To prevent dust irritation the wearing of a face mask is recommended.
4. While operating the machine, always wear non-slip and protective footwear. Non-skid, closed-toed safety boots and shoes will reduce the risk of injury.
5. Always wear rubber/chemical-resistant gloves and rubber/chemical boots when working with the machine.

## Handling of chemicals

1. Some chemicals may contain toxic and/or caustic substances. Such chemicals can be dangerous and cause serious or fatal injury to persons and animals and/or severe damage to plants and the environment. Avoid direct contact with chemicals. Follow the chemical manufacturer's instructions with respect to any contact with its product.
2. Read the manufacturer's label and instruction manual each time before mixing or using the chemical and before storing or disposal. Careless or improper use may cause serious or fatal injury.
3. Carefully read the labels on chemical containers before use. Chemicals are classified into categories of toxicity. Each category will have unique handling characteristics. Familiarize yourself with the characteristics for the category of the chemical you are using. Chemicals may be used only by persons trained in their handling and the appropriate first-aid measures.
4. Chemicals may be harmful to persons, animals and the environment if improperly used. It is advisable not to use some chemicals that are caustic, corrosive or poisonous with the machine.
5. Mix only compatible pesticides. Wrong mixtures can produce toxic fumes. When handling and spraying chemicals, make sure you are operating in accordance with your local environmental protection rules and guidelines. Do not spray when it is windy. To help protect the environment, use only the recommended dosage.

6. Avoid opening your mouth such as eating, drinking, or smoking while handling chemicals or while you are spraying. Never blow through nozzles, tubes, pipes or any other component by your mouth. Always handle chemicals in a well-ventilated area while wearing appropriate protective clothing and safety equipment.
7. Do not store or transport chemicals together with food, drink, or medicines, and never reuse a chemical container for any other purposes. Do not transfer liquid chemicals to other containers, especially food and/or drink containers.
8. Keep the product's label ready to read to or show the persons you consult. Clean all chemical spills immediately. In case of accidental contact or ingestion of chemicals or in case of contamination of clothing, stop working and immediately consult the chemical manufacturer's instructions. If doubtful about what to do, ask a doctor or poison control center for advice immediately.
9. Dispose of any residue observing the laws and regulations of your region of residence.
10. Keep chemicals out of reach of children, other unauthorized people and animals. When not in use, store chemicals in a safe and locked place. Follow the manufacturer's recommendations for proper storage.

## Preparing chemicals

1. Prepare chemical solutions following the chemical manufacturer's instructions.
2. Prepare solution only enough for the job at hand so that no solution is left over.
3. Mix chemicals only by following instructions. Wrong mixtures can produce toxic fumes or explosive mixtures.
4. Never spray undiluted chemicals.
5. Prepare solution and fill the container outdoors only in a well-ventilated place.

## Storing chemicals

1. Do not store spray solution in the container for more than one day.
2. Always store and transport spray solution only in approved containers.
3. Never store or transport the spray solution in containers intended for foods, drinks or animal feed.
4. Do not store or transport spray solution with foods, drinks or animal feed.
5. Keep spray solution out of the reach of children, other unauthorized people and animals.
6. Store the spray solution in a locked place secured against unauthorized use.

## Disposing of chemicals

1. Never dispose of residual chemicals or contaminated rinsing solutions in waterways, drains, sewers, street gutters, manholes or the like.
2. When disposing of contaminated rinse, observe your all applicable laws, regulations and ordinances.
3. Strictly observe the precautionary instructions of the chemical manufacturer.

### Filling the tank

1. Make sure that the draining lever and nozzle lever are closed.
2. Before using the mist blower with chemicals, fill the tank with fresh water to assure that you have assembled it properly and practice spraying. Also, check for any leaks at this time. When thoroughly familiar with the mist blower operation, follow normal operating procedures.
3. Fill the tank in well-ventilated areas or outdoors.
4. Do not use flammables in the mist blower, which may cause explosion resulting in serious or fatal injury.
5. Do not use caustic or corrosive materials in the mist blower, which could result in damage to the machine.
6. Do not use liquid with temperature exceeds 50 °C (122 °F) to reduce the risk of scalding and damage to the machine.
7. To fill the tank, place the mist blower on a level surface. To reduce the risk of contaminating the surrounding environment, be careful not to overflow the tank with chemical solution.
8. To reduce the risk of injury, do not fill the tank while wearing the machine on your back.
9. If you fill the solution container with a hose attached to a central water supply, be sure the end of the hose is out of the solution to reduce the risk of backflow.
10. Calculate the correct amount of chemical solution so that it is used up at one time, with no extra solution left over in the tank.
11. After filling, tighten the tank cap firmly.
12. Check for leakage while refilling and during operation. A leak from the tank or a loose fitting could soak your clothing and come into contact with your skin.
13. Fill the tank with liquid according to operator's body size or strength.

### Operation

1. Switch off the machine and remove the battery cartridges and make sure that all moving parts have come to a complete stop
  - whenever you leave the machine.
  - before clearing blockages.
  - before checking, cleaning or working on the machine.
  - if the machine starts to vibrate abnormally.
2. Operate the machine only in daylight or in good artificial light.
3. Do not overreach and keep proper balance and footing at all times.
4. Always be sure of your footing on slopes.
5. Walk, never run.
6. Keep all cooling air inlets clear of debris.
7. Never spray in the direction of bystanders.
8. Operate the machine in a recommended position and on a firm surface.
9. Do not operate the machine at high places.

10. Never point the nozzle at anyone in the vicinity when using the machine.
11. Never block suction inlet and/or mist blower outlet.
  - Be careful not to block suction inlet or mist blower outlet with dust or dirt when operating in dusty area.
  - Do not use nozzles other than the nozzles provided by Makita.
12. Do not operate the machine near open window, etc.
13. Operating the machine only at reasonable hours is recommended - not early in the morning or late at night when people might be disturbed.
14. If the machine strikes any foreign objects or should start making any unusual noise or vibration, immediately switch off the machine to stop it. Remove the battery cartridges from the machine and inspect the machine for damage before restarting and operating the machine. If the machine is damaged, ask Makita Authorized Service Centers for repair.
15. Do not insert fingers or other objects into suction inlet or mist blower outlet.
16. Prevent unintentional starting. Ensure the switch is in the off-position before inserting battery cartridges, picking up or carrying the machine. Carrying the machine with your finger on the switch or energizing the machine that has the switch on invites accidents.
17. Do not operate the machine near flammable materials.
18. Avoid operating the machine for a long time in low temperature environment.
19. Do not use the machine when there is a risk of lightning.
20. When you use the machine on muddy ground, wet slope, or slippery place, pay attention to your footing.
21. Do not use the machine in bad weather where visibility is limited. Failure to do so may cause fall or incorrect operation due to low visibility.
22. Do not submerge the machine into a puddle.
23. Do not leave the machine unattended outdoors in the rain.
24. Do not use the machine in the snow.
25. During operation, keep the cord away from obstacles. The cord caught by obstacles may cause serious injury.
26. Avoid working in freezing temperatures as the liquid in the tank may freeze.

### After operation

1. Always wash yourself thoroughly with soap and water after spraying or handling chemicals. Shower immediately, and wash all protective clothing separately from other items. Follow any additional recommendations of the chemical manufacturer.



2. Empty, rinse and clean the tank and strainer after each use. This helps to prevent the solution from crystallizing, which could later cause clogging and chemical damage to the machine. In addition, residual chemicals may have undesirable effects during subsequent spraying with a different type of chemical (e.g., residual herbicide may damage or kill plants being sprayed with a pesticide).
3. Do not store the machine with spray solution in the tank.
5. Do not use a battery pack or tool that is damaged or modified. Damaged or modified batteries may exhibit unpredictable behaviour resulting in fire, explosion or risk of injury.
6. Do not expose a battery pack or tool to fire or excessive temperature. Exposure to fire or temperature above 130 °C may cause explosion.
7. Follow all charging instructions and do not charge the battery pack or tool outside the temperature range specified in the instructions. Charging improperly or at temperatures outside the specified range may damage the battery and increase the risk of fire.

#### Maintenance and storage

1. Keep all nuts, bolts and screws tight to be sure the machine is in safe working condition.
2. If the parts are worn or damaged, replace them with parts provided by Makita.
3. Store the machine in a dry place out of the reach of children.
4. When you stop the machine for inspection, servicing, storage, or changing accessory, switch off the machine and make sure that all moving parts come to a complete stop, and remove the battery cartridges. Cool down the machine before making any work on the machine. Maintain the machine with care and keep it clean.
5. Always cool down the machine before storing.
6. Do not expose the machine to rain. Store the machine indoors.
7. When you lift the machine, be sure to bend your knees and be careful not to hurt your back.
8. When washing the machine, do not let water enter the electrical mechanism such as battery, motor, and terminals.
9. When storing the machine, avoid direct sunlight and rain, and store it in a place where it does not get hot or humid.
10. When carrying the machine, be sure to hold the machine firmly.
11. When carrying the machine, be careful not to get the cord caught by obstacles.

#### Battery tool use and care

1. Recharge only with the charger specified by the manufacturer. A charger that is suitable for one type of battery pack may create a risk of fire when used with another battery pack.
2. Use power tools only with specifically designed battery packs. Use of any other battery packs may create a risk of injury and fire.
3. When battery pack is not in use, keep it away from other metal objects, like paper clips, coins, keys, nails, screws or other small metal objects, that can make a connection from one terminal to another. Shorting the battery terminals together may cause burns or a fire.
4. Under abusive conditions, liquid may be ejected from the battery; avoid contact. If contact accidentally occurs, flush with water. If liquid contacts eyes, additionally seek medical help. Liquid ejected from the battery may cause irritation or burns.

#### Electrical and battery safety

1. Do not dispose of the battery(ies) in a fire. The cell may explode. Check with local codes for possible special disposal instructions.
2. Do not open or mutilate the battery(ies). Released electrolyte is corrosive and may cause damage to the eyes or skin. It may be toxic if swallowed.
3. Do not charge battery in rain, or in wet locations.
4. Do not charge the battery outdoors.
5. Do not handle charger, including charger plug, and charger terminals with wet hands.
6. Do not replace the battery with wet hands.
7. Do not replace the battery in the rain.
8. Do not wet the terminal of battery with liquid such as water, or submerge the battery. Do not leave the battery in the rain, nor charge, use, or store the battery in a damp or wet place. If the terminal gets wet or liquid enters inside of battery, the battery may be short circuited and there is a risk of overheat, fire, or explosion.
9. After removing the battery from the machine or charger, be sure to store it in a dry place.
10. If the battery cartridge gets wet, drain the water inside and then wipe it with a dry cloth. Dry the battery cartridge completely in a dry place before use.

#### Service

1. Have your power tool serviced by a qualified repair person using only identical replacement parts. This will ensure that the safety of the power tool is maintained.
2. Never service damaged battery packs. Service of battery packs should only be performed by the manufacturer or authorized service providers.

## SAVE THESE INSTRUCTIONS.

**⚠WARNING:** DO NOT let comfort or familiarity with product (gained from repeated use) replace strict adherence to safety rules for the subject product.

MISUSE or failure to follow the safety rules stated in this instruction manual may cause serious personal injury.



## Important safety instructions for battery cartridge

1. Before using battery cartridge, read all instructions and cautionary markings on (1) battery charger, (2) battery, and (3) product using battery.
2. Do not disassemble or tamper with the battery cartridge. It may result in a fire, excessive heat, or explosion.
3. If operating time has become excessively shorter, stop operating immediately. It may result in a risk of overheating, possible burns and even an explosion.
4. If electrolyte gets into your eyes, rinse them out with clear water and seek medical attention right away. It may result in loss of your eyesight.
5. Do not short the battery cartridge:
  - (1) Do not touch the terminals with any conductive material.
  - (2) Avoid storing battery cartridge in a container with other metal objects such as nails, coins, etc.
  - (3) Do not expose battery cartridge to water or rain.

A battery short can cause a large current flow, overheating, possible burns and even a breakdown.

6. Do not store and use the tool and battery cartridge in locations where the temperature may reach or exceed 50 °C (122 °F).
7. Do not incinerate the battery cartridge even if it is severely damaged or is completely worn out. The battery cartridge can explode in a fire.
8. Do not nail, cut, crush, throw, drop the battery cartridge, or hit against a hard object to the battery cartridge. Such conduct may result in a fire, excessive heat, or explosion.
9. Do not use a damaged battery.
10. The contained lithium-ion batteries are subject to the Dangerous Goods Legislation requirements.

For commercial transports e.g. by third parties, forwarding agents, special requirement on packaging and labeling must be observed.  
For preparation of the item being shipped, consulting an expert for hazardous material is required.  
Please also observe possibly more detailed national regulations.  
Tape or mask off open contacts and pack up the battery in such a manner that it cannot move around in the packaging.
11. When disposing the battery cartridge, remove it from the tool and dispose of it in a safe place. Follow your local regulations relating to disposal of battery.
12. Use the batteries only with the products specified by Makita. Installing the batteries to non-compliant products may result in a fire, excessive heat, explosion, or leak of electrolyte.

13. If the tool is not used for a long period of time, the battery must be removed from the tool.
14. During and after use, the battery cartridge may take on heat which can cause burns or low temperature burns. Pay attention to the handling of hot battery cartridges.
15. Do not touch the terminal of the tool immediately after use as it may get hot enough to cause burns.
16. Do not allow chips, dust, or soil stuck into the terminals, holes, and grooves of the battery cartridge. It may cause heating, catching fire, burst and malfunction of the tool or battery cartridge, resulting in burns or personal injury.
17. Unless the tool supports the use near high-voltage electrical power lines, do not use the battery cartridge near high-voltage electrical power lines. It may result in a malfunction or breakdown of the tool or battery cartridge.
18. Keep the battery away from children.

## SAVE THESE INSTRUCTIONS.

**CAUTION:** Only use genuine Makita batteries. Use of non-genuine Makita batteries, or batteries that have been altered, may result in the battery bursting causing fires, personal injury and damage. It will also void the Makita warranty for the Makita tool and charger.

## Tips for maintaining maximum battery life

1. Charge the battery cartridge before completely discharged. Always stop tool operation and charge the battery cartridge when you notice less tool power.
2. Never recharge a fully charged battery cartridge. Overcharging shortens the battery service life.
3. Charge the battery cartridge with room temperature at 10 °C - 40 °C (50 °F - 104 °F). Let a hot battery cartridge cool down before charging it.
4. When not using the battery cartridge, remove it from the tool or the charger.
5. Charge the battery cartridge if you do not use it for a long period (more than six months).

# ASSEMBLY

**CAUTION:** Always be sure that all the battery cartridges are removed before carrying out any work on the machine. Failure to remove all the battery cartridges may result in serious personal injury from accidental start-up.

## Assembling blower pipes

1. Loosen the clamp screw.

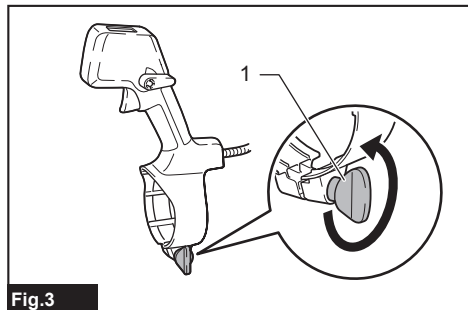

Fig.3

- 1. Clamp screw

2. Install the control handle to the swivel pipe and tighten the clamp screw.

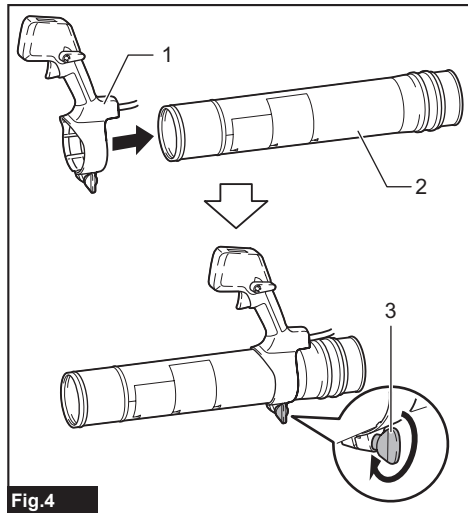

Fig.4

- 1. Control handle 2. Swivel pipe 3. Clamp screw

**NOTICE:** Be careful not to twist the cable of the control handle when attaching the control handle to the swivel pipe.

3. Loosen the screw on the hose clamp, and then attach the hose clamp to the end nozzle. Align the grooves on the end nozzle with the protrusions on the swivel pipe, then attach the end nozzle to the swivel pipe, and then tighten the screw on the hose clamp.

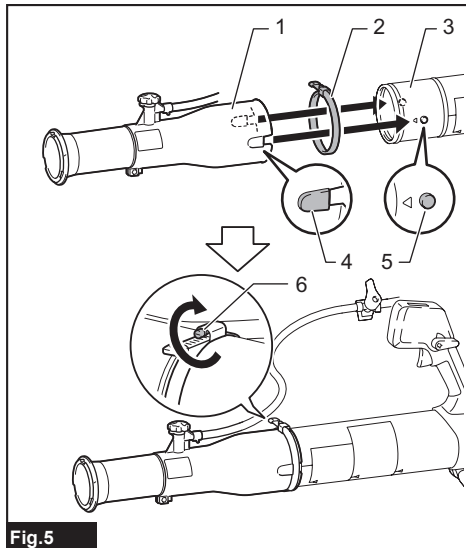

Fig.5

- 1. End nozzle 2. Hose clamp 3. Swivel pipe  
4. Groove 5. Protrusion 6. Screw

4. Loosen the screw on the hose clamp, then attach the nozzle lever to the hose clamp, and then attach the hose clamp to the flexible pipe. Attach the swivel pipe to the flexible pipe, and then tighten the screw on the hose clamp.

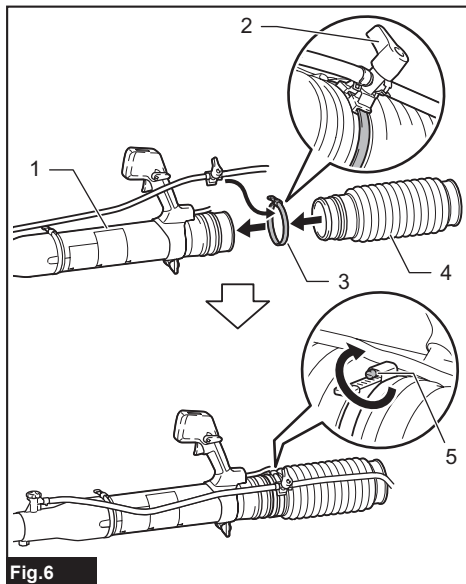

Fig.6

- 1. Swivel pipe 2. Nozzle lever 3. Hose clamp  
4. Flexible pipe 5. Screw

5. Loosen the screw on the hose clamp, and then attach the hose clamp to the flexible pipe. Attach the flexible pipe to the elbow, and then tighten the screw on the hose clamp.

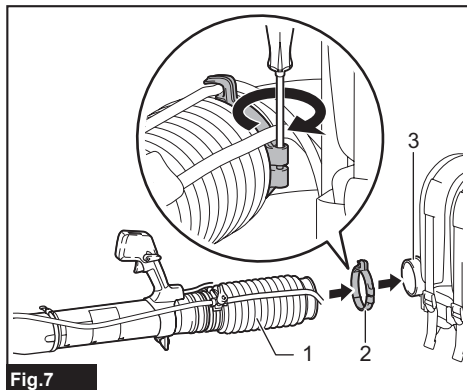

Fig.7

► 1. Flexible pipe 2. Hose clamp 3. Elbow

**NOTICE:** Make sure that the screw on the hose clamp is not facing outward as shown in the figure.

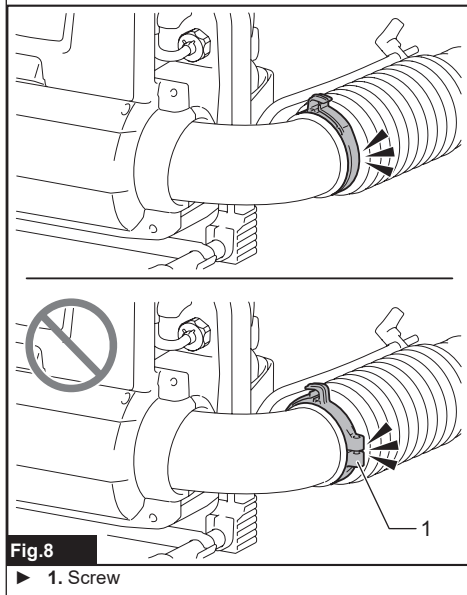

Fig.8

► 1. Screw

6. Clamp the control cable to the cable holders.

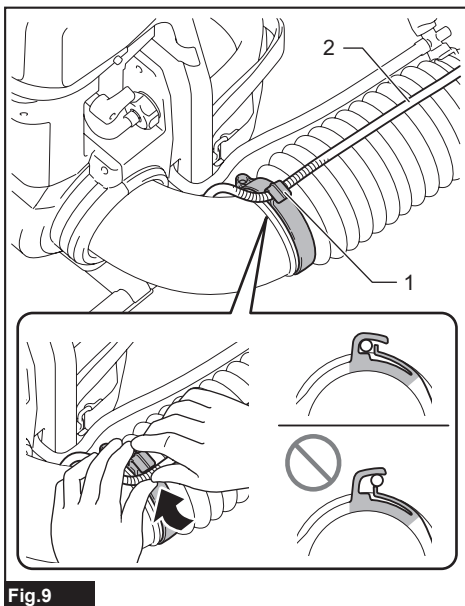

Fig.9

► 1. Cable holder 2. Control cable

**NOTICE:** Make sure that the control cable is securely fixed to the cable holder.

## Adjusting the belt and shoulder harness

1. Put on the machine, then lock the buckle of the waist belt, and then adjust the length of the waist belt.

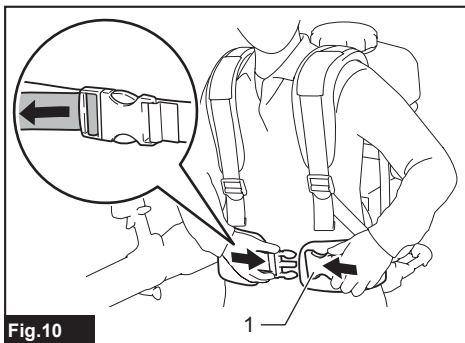

Fig.10

► 1. Buckle

2. Adjust the length of the shoulder harness.

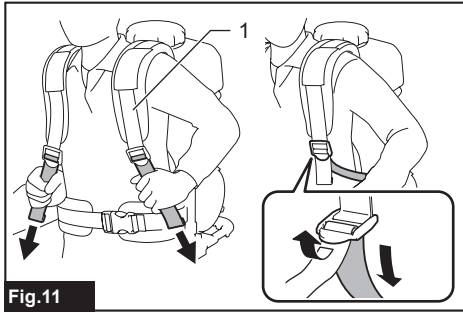

Fig.11

- 1. Shoulder harness

## Adjusting the control lever position

Loosen the clamp screw. Move the control handle along the swivel pipe to the most comfortable position, and then tighten the clamp screw.

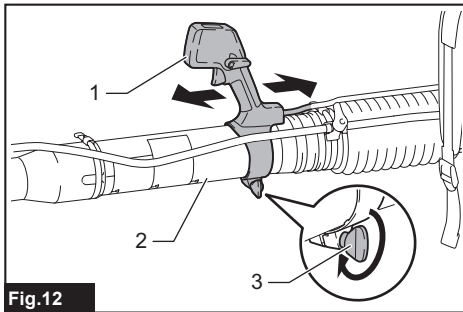

Fig.12

- 1. Control handle 2. Swivel pipe 3. Clamp screw

## Attaching the diffusion cover

You can diffuse the mist by attaching the diffusion cover to the end nozzle as shown in the figure.

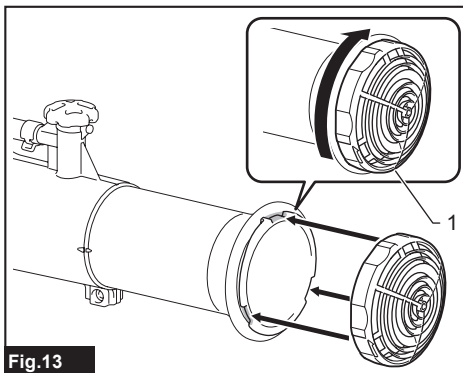

Fig.13

- 1. Diffusion cover

## Attaching the deflector

### Optional accessory

You can discharge the mist upward or downward by attaching the deflector to the end nozzle as shown in the figure.

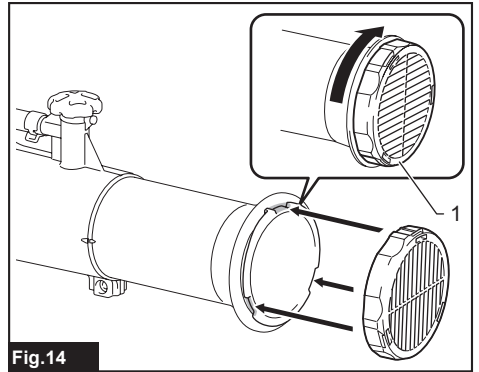

Fig.14

- 1. Deflector

## FUNCTIONAL DESCRIPTION

**CAUTION:** Always be sure that the machine is switched off and all the battery cartridges are removed before adjusting or checking function on the machine.

## Installing or removing battery cartridge

**CAUTION:** Always switch off the machine before installing or removing of the battery cartridge.

**CAUTION:** Hold the machine and the battery cartridge firmly when installing or removing battery cartridge. Failure to hold the machine and the battery cartridge firmly may cause them to slip off your hands and result in damage to the machine and battery cartridge and a personal injury.

**CAUTION:** Make sure that you lock the battery cover before use. Otherwise, mud, dirt, or water may cause damage to the product or the battery cartridge.

**CAUTION:** Always install the battery cartridge fully until the red indicator cannot be seen. If not, it may accidentally fall out of the machine, causing injury to you or someone around you.

**CAUTION:** Do not install the battery cartridge forcibly. If the cartridge does not slide in easily, it is not being inserted correctly.

**CAUTION:** Hold the battery cover firmly when installing or removing the battery cartridge.

### To install the battery cartridge;

1. Pull up the locking lever upward, and then open the battery cover.

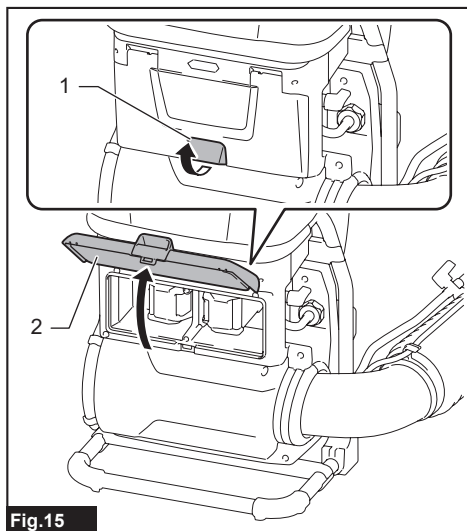

Fig.15

- 1. Locking lever 2. Battery cover

2. Align the tongue on the battery cartridge with the slot on the machine, and then slide the cartridge until it locks in place with a little click.

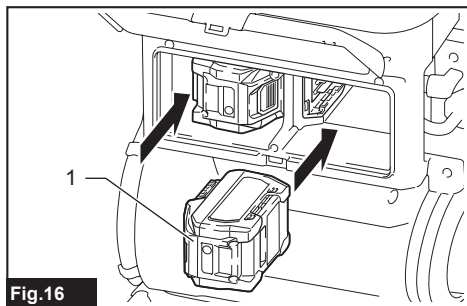

Fig.16

- 1. Battery cartridge

3. Close the battery cover and push it until it is latched with the locking lever.

### To remove the battery cartridge;

1. Pull up the locking lever and open the battery cover.
2. Pull out the battery cartridge from the machine while sliding the button on the front of the cartridge.

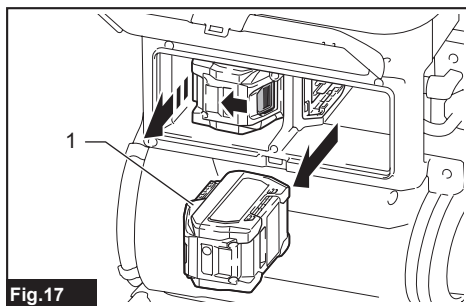

Fig.17

- 1. Battery cartridge

3. Close the battery cover.

### Battery check button

You can check the remaining battery capacity by pressing the battery check button.

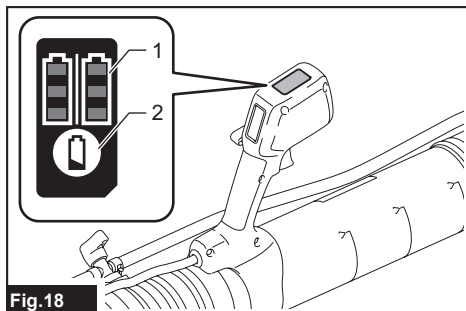

Fig.18

- 1. Battery indicator 2. Battery check button

Battery indicator status			Remaining battery capacity
On	Off	Blinking	
			50% to 100%
			20% to 50%
			0% to 20%

## Machine/battery protection system

**NOTE:** The indicator lamp for remaining battery capacity is just for a reference. The actual battery capacity may differ depending on the usage conditions or ambient temperature.

**NOTE:** While the machine is in operation, the indicator lamp does not light up even if you press the check button.

**NOTE:** The lamp automatically goes off after a few seconds.

**NOTE:** If two battery cartridges are installed, the battery installed on the right side is used first.

**NOTE:** If two battery cartridges are installed, the machine automatically switches the battery when the battery in use becomes empty.

## Indicating the remaining battery capacity

Press the check button on the battery cartridge to indicate the remaining battery capacity. The indicator lamps light up for a few seconds.

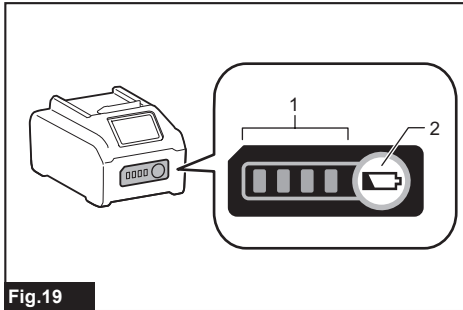

Fig.19

► 1. Indicator lamps 2. Check button

Indicator lamps			Remaining capacity
Lighted	Off	Blinking	
■ ■ ■ ■			75% to 100%
■ ■ ■ □			50% to 75%
■ ■ □ □			25% to 50%
■ □ □ □			0% to 25%
▣ □ □ □			Charge the battery.
■ ■ □ □			The battery may have malfunctioned.
□ □ ■ ■			

**NOTE:** Depending on the conditions of use and the ambient temperature, the indication may differ slightly from the actual capacity.

**NOTE:** The first (far left) indicator lamp will blink when the battery protection system works.

The machine is equipped with a machine/battery protection system. This system automatically cuts off power to the motor to extend machine and battery life. The machine will automatically stop during operation if the machine or battery is placed under one of the following conditions:

### Overload protection

When the machine or battery is operated in a manner that causes it to draw an abnormally high current, the machine automatically stops and the main power lamp blinks in green. In this situation, turn the machine off and stop the application that caused the machine to become overloaded. Then turn the machine on to restart.

### Overheat protection

When the machine is overheated, the machine stops automatically and the main power lamp lights up in red. In this case, let the machine and battery cool before turning the machine on again.

**NOTE:** The main power lamp blinks in red when the battery is overheated.

### Overdischarge protection

When the battery capacity is not enough, the machine stops automatically and the main power lamp blinks in red. In this case, remove the battery from the machine and charge the battery or change the battery to fully charged one.

### Protections against other causes

Protection system is also designed for other causes that could damage the machine and allows the machine to stop automatically. Take all the following steps to clear the causes, when the machine has been brought to a temporary halt or stop in operation.

1. Turn the machine off, and then turn it on again to restart.
2. Charge the battery(ies) or replace it/them with recharged battery(ies).
3. Let the machine and battery(ies) cool down.

If no improvement can be found by restoring protection system, then contact your local Makita Service Center.

**NOTICE:** If the machine stops due to a cause not described above, refer to the section for troubleshooting.

## Main power switch

**⚠ WARNING:** Always turn off the main power switch when not in use.

To turn on the machine, press the main power switch. The lamps light up in green. To turn off, press and hold the main power switch until the lamps go off.

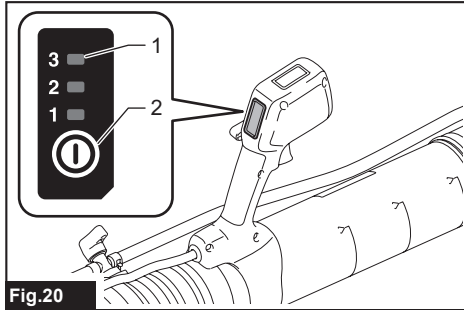

Fig.20

► 1. Speed indicator 2. Main power switch

The speed can be changed in three levels. To change the speed mode, press the main power switch. When you change the speed mode, the corresponding speed indicators light up.

**NOTE:** The machine employs the auto power-off function. To avoid unintentional start up, the main power switch will automatically shut down when the machine is not operated for a certain period after the main power switch is turned on.

**NOTE:** If the main power lamp lights up in red or blinks in red or green, refer to the instructions for machine/battery protection system.

## Switch action

**⚠ WARNING:** Before installing the battery cartridge into the machine, always check to see that the switch trigger actuates properly and returns to the "OFF" position when released.

To start the machine, pull the switch trigger. The speed increases by increasing pressure on the switch trigger. Release the switch trigger to stop.

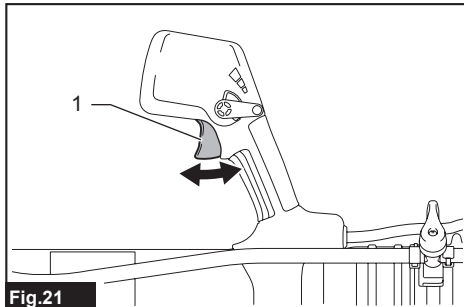

Fig.21

► 1. Switch trigger

## Cruise control function

The cruise control function allows the operator to maintain a constant speed without pulling the trigger. To increase the speed, turn the control lever forward. To decrease the speed, turn the control lever backward.

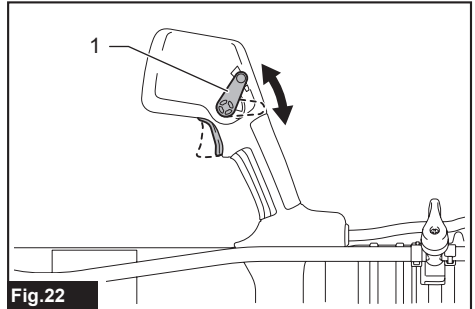

Fig.22

► 1. Control lever

## Opening and closing the levers

The machine is equipped with three levers.

### Nozzle lever

The nozzle lever is used for blowing mist. Normally, close the nozzle lever, and open the nozzle lever only when blowing mist.

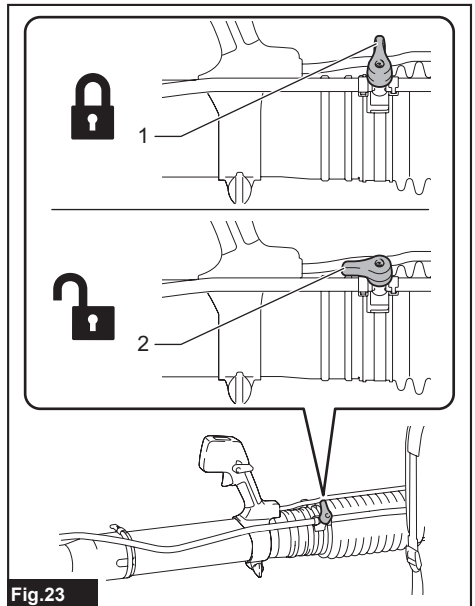

Fig.23

► 1. Closed 2. Open



## Draining lever

The draining lever is used for draining the liquid in the tank. When operating the machine, always close the lever.

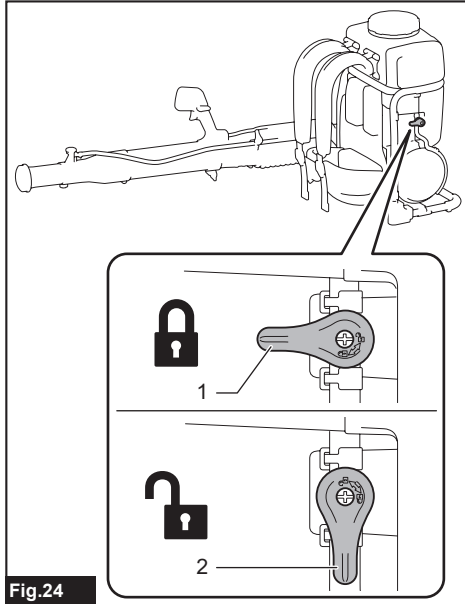

Fig.24

► 1. Closed 2. Open

## Tank lever

The tank lever is used when replacing the filter. When operating the machine, always open the lever.

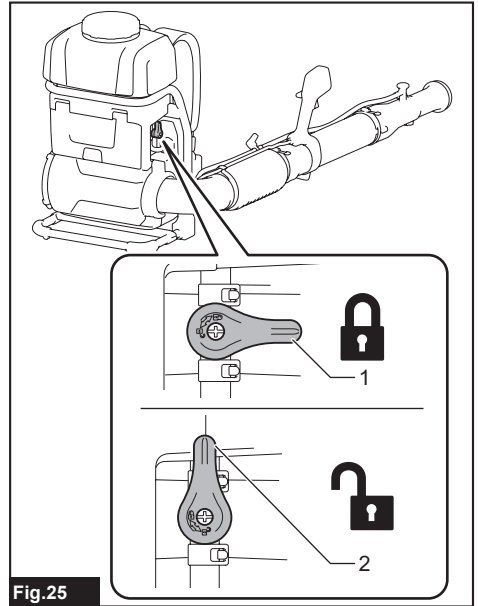

Fig.25

► 1. Closed 2. Open

## Feed amount adjustment knob

You can adjust the amount of liquid fed to the end nozzle. To feed the maximum amount of liquid, turn the knob so that "4" is aligned with the triangular mark. To feed the minimum amount of liquid, turn the knob so that "1" is aligned with the triangular mark.

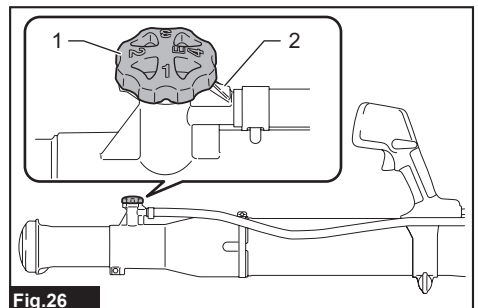

Fig.26

► 1. Feed amount adjustment knob 2. Triangular mark

## Electronic function

The machine is equipped with the electronic function for easy operation.

- Constant speed control  
The speed control function provides the constant rotation speed regardless of load conditions.
- Feed valve function  
The machine is equipped with the feed valve. The feed valve automatically opens to feed the liquid in the tank when the switch trigger is pulled, and it automatically closes when the switch trigger is released.

## Accidental re-start preventive function

When you turn on the machine while pulling the switch trigger, the machine does not start and the main power lamp blinks in green. To start the machine, first release the switch trigger and return the control lever fully, and then turn on the machine.

## OPERATION

**⚠ CAUTION:** When putting on the machine, be sure to put shoulder harness on your both shoulders. Otherwise, the machine may fall when you put on or use the machine, and cause an injury.

**⚠ CAUTION:** When putting on the machine, be sure to put on the machine on your back. Otherwise, the machine may fall during operation and cause an injury.

**⚠ CAUTION:** Do not place the machine on the ground while it is running. Sand or dust may enter from suction inlet and cause a malfunction or personal injury.

Before operating the machine, adjust the length of the shoulder harness and the waist belt.

1. Place the machine on a flat and stable surface.
  2. Make sure that the levers are in the following positions.
- The draining lever is in the closed position.

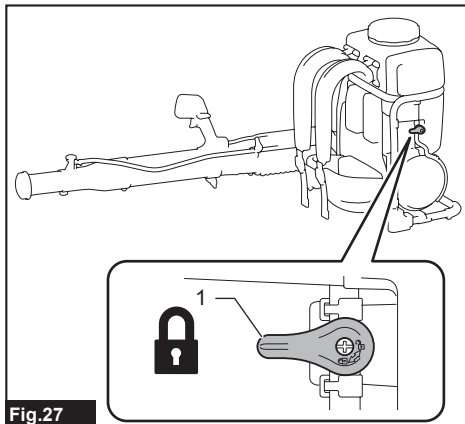

Fig.27

- 1. Draining lever

- The tank lever is in the open position.

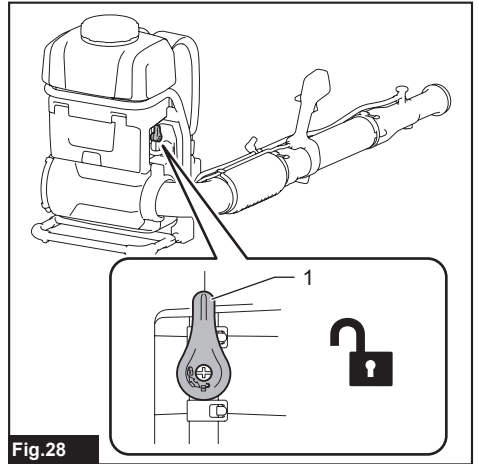

Fig.28

- 1. Tank lever

- The nozzle lever is in the closed position.

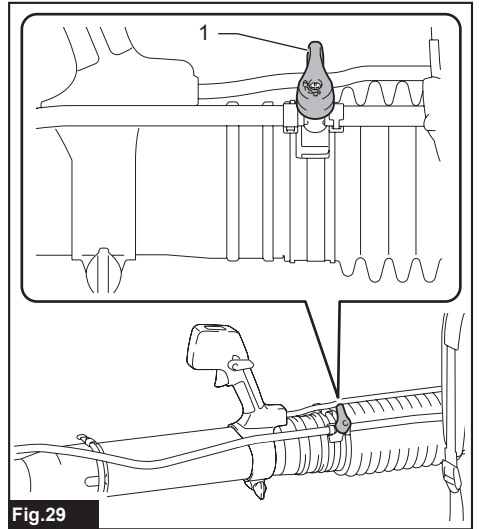

Fig.29

- 1. Nozzle lever

3. Open the tank cap, and then set the strainer.

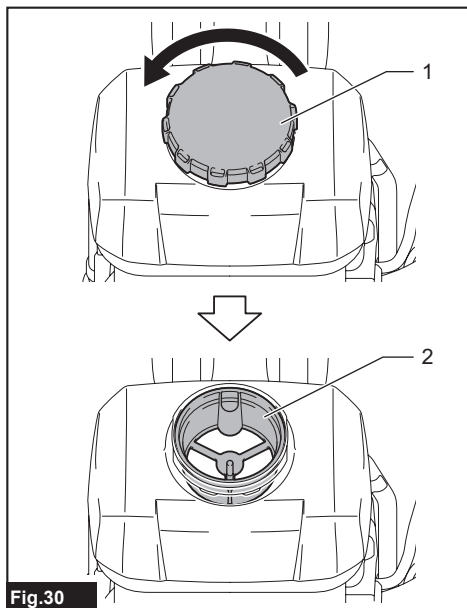

Fig.30

► 1. Tank cap 2. Strainer

4. Pour the liquid into the tank, and then tighten the tank cap.

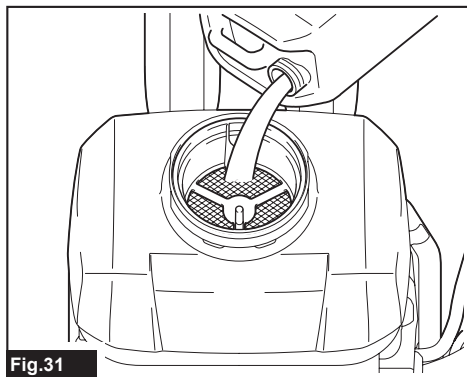

Fig.31

5. Put on the machine, then lock the buckle of the waist belt.

6. Turn the nozzle lever so that the nozzle lever is in the open position.

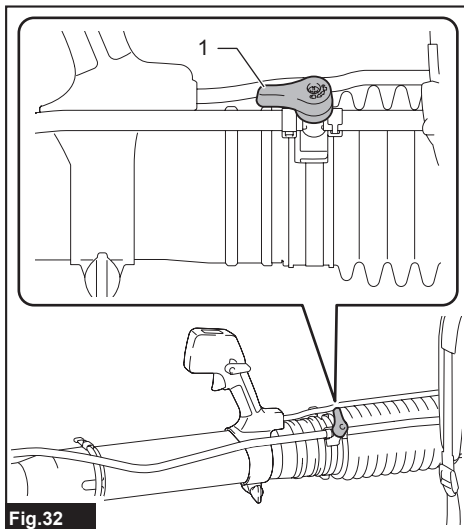

Fig.32

► 1. Nozzle lever

7. Turn on the machine, and then hold the control handle firmly and perform the mist blowing operation. After the operation, turn the nozzle lever so that the nozzle lever is in the closed position.

When setting down the machine, unlock the buckle of the waist belt, and then set down the machine slowly.

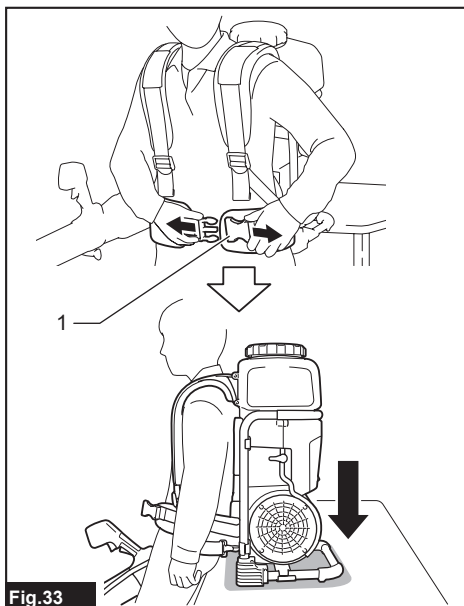

Fig.33

► 1. Buckle

**NOTE:** You can stir the liquid in the tank by turning the strainer as shown in the figure.

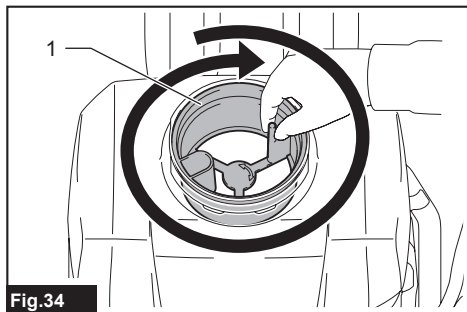

Fig.34

► 1. Strainer

## MAINTENANCE

**CAUTION:** Always be sure that all the battery cartridges are removed from the machine before storing or carrying the machine or attempting to perform inspection or maintenance.

To maintain product SAFETY and RELIABILITY, repairs, any other maintenance or adjustment should be performed by Makita Authorized or Factory Service Centers, always using Makita replacement parts.

### Draining the liquid

When draining the liquid in the tank, remove the hose from the main unit, and then drain the liquid in the tank into the container by opening the draining lever. After draining the liquid, be sure to close the draining lever, and attach the hose to the main unit.

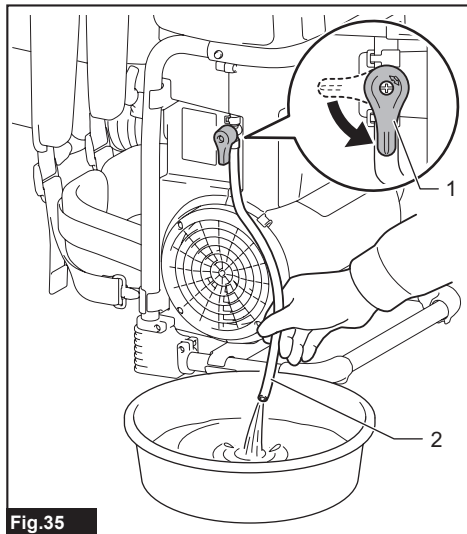

Fig.35

► 1. Draining lever 2. Hose

**NOTE:** To empty the tank completely, tilt the main unit slightly toward the outlet of hose.

### Cleaning the machine

**NOTICE:** Never use gasoline, benzine, thinner, alcohol or the like. Discoloration, deformation or cracks may result.

Clean the machine by wiping off dust with a dry cloth or one dipped in soapy water and wrung out.

Remove dust or dirt from the suction inlet.

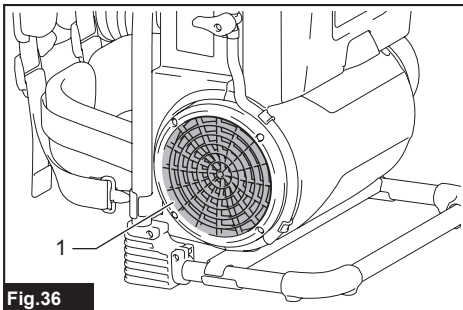

Fig.36

► 1. Suction inlet

### Cleaning the filter

Clean the filter regularly. To clean the filter, follow the steps below.

1. Remove the battery cartridges, and then close the tank lever.
2. Remove the filter cap by turning it counterclockwise, and then remove the filter.

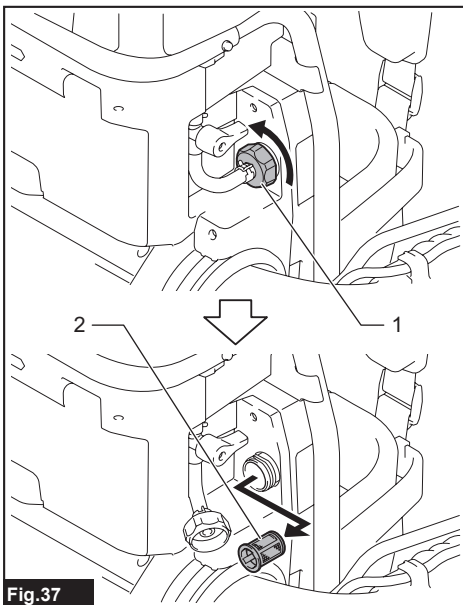

Fig.37

► 1. Filter cap 2. Filter

- Clean the filter with running water.
- Attach the filter to the main unit, and then tighten the filter cap.
- Open the tank lever.

## Storage

Before storing the machine, perform full maintenance. Store the machine in a place out of the reach of children and not exposed to moisture, rain, or direct sunlight. You can connect the band of the pipe to the machine as shown in the figure to stand up the pipe.

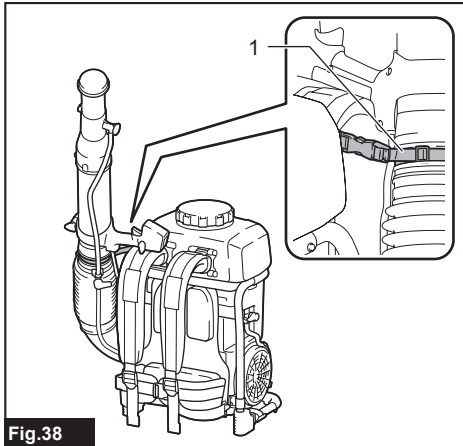

Fig.38

- 1. Band

## Changing the nozzle

You can change the standard nozzle to the ULV (Ultra Low Volume) nozzle. The ULV nozzle can discharge finer mist than the standard nozzle. To change the nozzle, follow the steps below.

- Loosen the screw and remove it, and then remove the front side of the end nozzle.

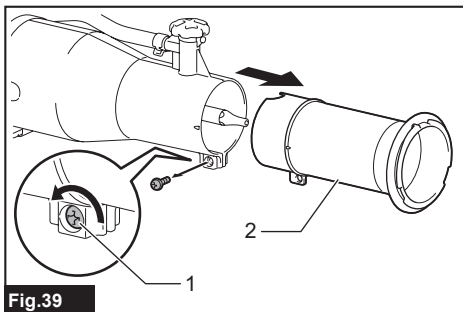

Fig.39

- 1. Screw 2. End nozzle

- Remove the standard nozzle by turning the nozzle counterclockwise using the wrench.

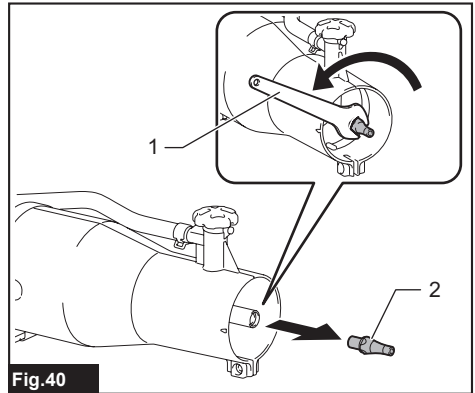

Fig.40

- 1. Wrench 2. Standard nozzle

- Remove the O-ring from the standard nozzle, and then attach it to the ULV nozzle.

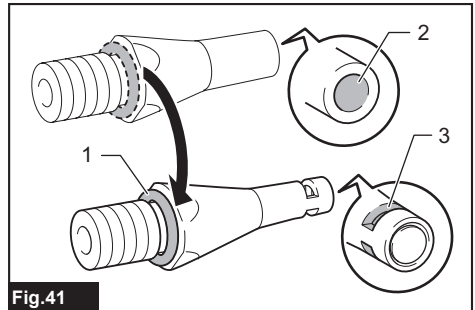

Fig.41

- 1. O-ring 2. Standard nozzle 3. ULV nozzle

- Attach the ULV nozzle by turning the nozzle clockwise using the wrench.

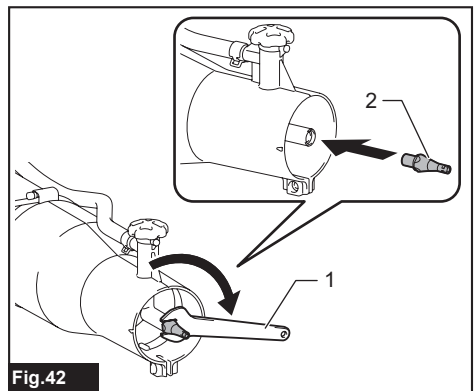

Fig.42

- 1. Wrench 2. ULV nozzle

**NOTICE:** Do not tighten the nozzle too much. The recommended tightening torque is approximately 1.0 N·m. Tightening the nozzle too much may damage the mounting part for nozzle.

5. Attach the end nozzle, and then tighten the screw.

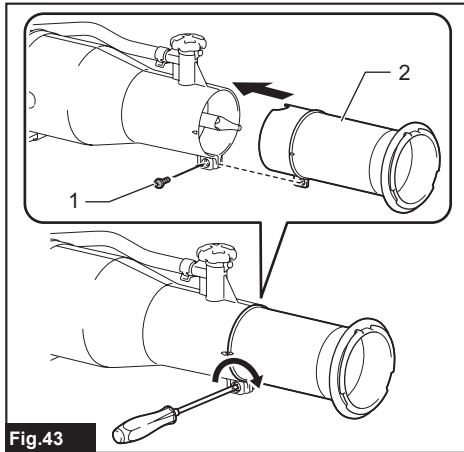

Fig.43

- 1. Screw 2. End nozzle

## TROUBLESHOOTING

Before asking for repairs, conduct your own inspection first. If you find a problem that is not explained in the manual, do not attempt to dismantle the machine. Instead, ask Makita Authorized Service Centers, always using Makita replacement parts for repairs.

State of abnormality	Probable cause (malfunction)	Remedy
Motor does not run.	Battery is not installed.	Install the battery.
	Battery problem (under voltage)	Recharge the battery. If recharging is not effective, replace battery.
	The drive system does not work correctly.	Ask your local authorized service center for repair.
Motor stops running after a little use.	Battery's charge level is low.	Recharge the battery. If recharging is not effective, replace battery.
	Overheating.	Stop using the machine to allow it to cool down.
Mist is not discharged.	Tank is empty.	Fill the tank with liquid.
	Nozzle lever or tank lever is closed.	Open the nozzle lever and tank lever.
	Nozzle is clogged.	Remove the standard nozzle or ULV nozzle, and then clean the nozzle with running water to remove the clogged material.
	Filter is clogged.	Remove the filter, and then clean the filter with running water to remove the clogged material.
The machine does not reach the maximum speed.	Battery is installed improperly.	Install the battery as described in this manual.
	Battery power is dropping.	Recharge the battery. If recharging is not effective, replace battery.
	The drive system does not work correctly.	Ask your local authorized service center for repair.
Abnormal vibration: ⇒ stop the machine immediately!	The drive system does not work correctly.	Ask your local authorized service center for repair.
Motor cannot stop: ⇒ Remove the battery immediately!	Electric or electronic malfunction.	Remove the battery and ask your local authorized service center for repair.

# OPTIONAL ACCESSORIES

**⚠ CAUTION:** These accessories or attachments are recommended for use with your Makita product specified in this manual. The use of any other accessories or attachments might present a risk of injury to persons. Only use accessory or attachment for its stated purpose.

If you need any assistance for more details regarding these accessories, ask your local Makita Service Center.

- Deflector
- Makita genuine battery and charger

**NOTE:** Some items in the list may be included in the product package as standard accessories. They may differ from country to country.





**Makita Corporation**  
3-11-8, Sumiyoshi-cho,  
Anjo, Aichi 446-8502 Japan  
[www.makita.com](http://www.makita.com)

885A15-901 EN 20221116
------------------------------